



SLi6Pro Inverted Fluorescence Microscope User's Manual



Version 1.0



CONTENTS

1. Introduction	3	5. Camera Installation	
Disclaimer	3	5.1 Installing SeBaCam	17
Safety Conventions	3		
Prior to use	4	6. Troubleshooting	18, 19
2. Components	5	Optical System	
		Mechanical System	
		Electrical System	
		LED Fluorescence Assembly	
3. Assembly	6	7. Care and Maintenance	18
3.1 Assembly Precautions	6	1. Maintenance Procedures	19
3.2 Assembly Steps	6	2. Semi-Annual Preventive Care Routine	19
3.2.1 Objective Assembly	7	3. Recommended Preventive Maintenance	20
3.2.2 State Plate Assembly	7	4. Statement of Limited Product Warranty	20
3.2.3 Eyepiece Assembly	8		
3.2.4 Phase Contrast Slider Ass'y	8	8. Customer and Technical Service	21
3.2.5 Color Filter Assembly	8	Return Goods Policy	21
3.2.6 Stage Ext. & Mechanical Stg	8,9	Microscope Packing Instructions	21
3.2.7 Power Cord	9		
3.2.8 Replacing Transmitted LED	9		
3.2.9 Set Transmitted Illumination	10		
4. Operation			
4.2.1 Specimen Placement	10		
4.2.2 Operating Mechanical Stage	11		
4.2.3 Focus Adjustment	11		
4.2.4 Focus Tension Adjustment	11, 12		
4.2.5 Diopter Adjustment	12		
4.2.6 Interpupillary Distance Adj.	12		
4.2.7 Aperture Diaphragm Adjust.	13		
4.2.8 Use of Eyecup	13		
4.2.9 Use of Color Filters	13, 14		
4.2.10 Condenser Lens Removal	14		
4.2.11 Enhanced Dark Contrast	14		
4.2.12 Multi-illumination Contrast	14		
4.2.13 Darkroom Light Shield	16		
4.2.14 Installing Fluorescence illum.	16		
4.2.15 Using Fluorescence LEDs	16		

1. INTRODUCTION

DISCLAIMER

Information provided by Laxco Inc. is believed to be accurate and reliable. However, no responsibility is assumed by Laxco Inc. for its use. The information contained in this publication is subject to change without notice. Words that Laxco Inc. considers trademarks have been identified as such. However, neither the presence nor absence of such identification affects the legal status of any trademark. Units of measurement in this document conform to SI standards and practices. All rights reserved. No part of this publication may be reproduced, stored in a retrieval system, or transmitted in any form, be it electronically, mechanically, or by any other means such as photocopying, recording, or otherwise, without the prior written permission of Laxco Inc.

SYMBOL	DESCRIPTION
	STOP DAMAGE MAY OCCUR
	READ THE MANUAL BEFORE USE. UNSUITABLE OPERATION WOULD LEAD TO INJURY OR INSTRUMENT FAILURE
	SWITCH IS ON
0	SWITCH IS OFF

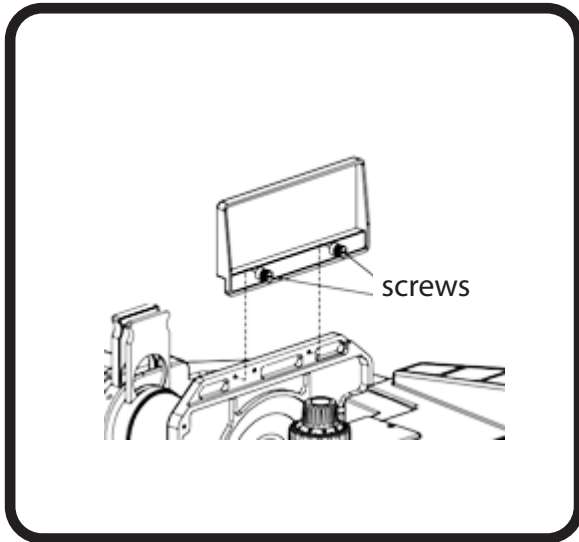

Attach the stage extension or mechanical stage as follows:

1. Screw the lock-screws (1) into the bottom of the stage extension or mechanical stage.
2. Screw it into the bottom of the stage.

3-2-7 POWER CORD

1. Turn the power switch (1) to the “o” OFF position before connecting the power cord.
2. Insert the plug into the external power supply into the outlet on the back of the microscope.
3. Insert the power plug into the power supply.
4. Insert the 3-prong plug (6) into a grounded outlet.

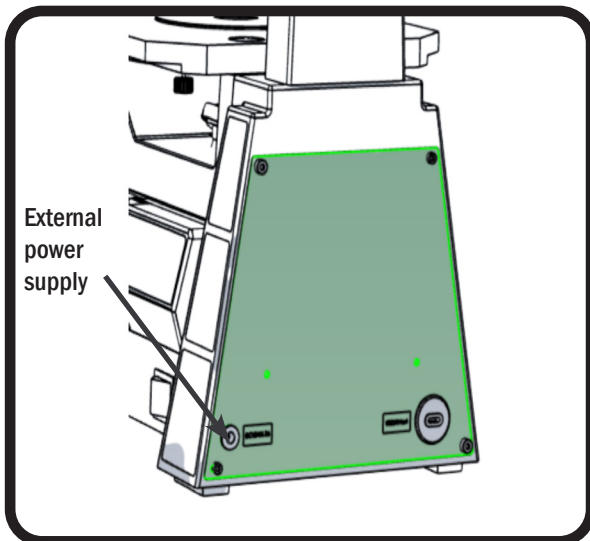

3-2-8 Replacing the Transmitted LED

1. Remove the screws with allen wrench.
2. Remove the LED module.
3. Gently insert new LED module to avoid damage.
4. Replace screws.
5. Connect the power cord, and turn the On/Off switch to the “on” position.

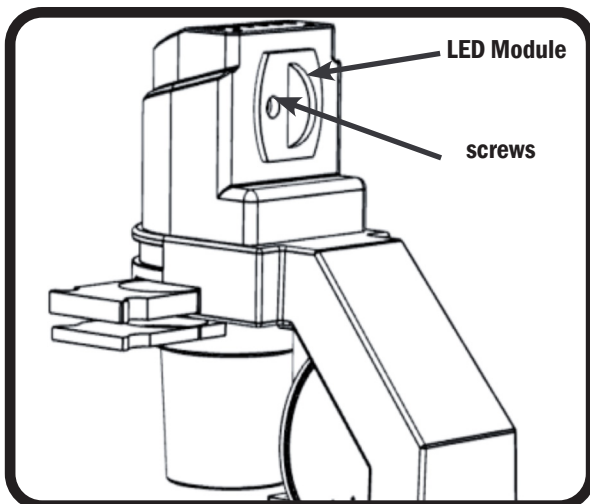

- Before attempting to replace or remove the LED, unplug the microscope from all power sources, turn the power switch to the “off” position.

PRIOR TO USE

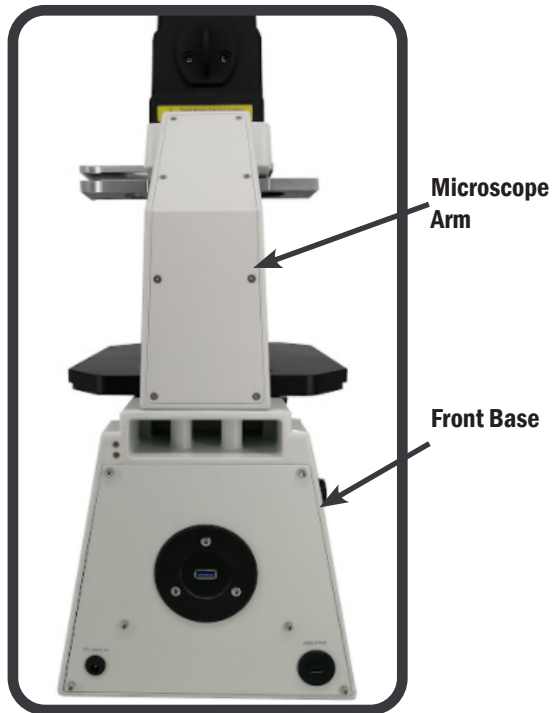

1. The microscope is a precision instrument. Please operate properly avoiding vibration or sudden jolting the microscope during operation.
2. Do not operate the microscope in direct sunlight, high temperature, high humidity, dusty environment, or close to sources of vibration. Ensure the work surface is level and flat.
3. When lifting or carrying the microscope, use one hand to grab the arm of the microscope and another hand to carry the front base.

The microscope will be damaged if the stage, focus knobs, or head are held when moving.



4. Ensure the microscope is properly grounded to avoid electric shock.
5. Ensure the power switch is in the "0" (off) position.
6. The input voltage is clearly marked on the back of the microscope. Ensure the power supply voltage is in this range.

MAINTENANCE

1. Utilizing a lens tissue moistened with a small amount of lens cleaning solution, gently wipe the eyepieces and condenser removing all oil and fingerprints on the optical surfaces.

Lens cleaning solution may be flammable. Turning on or off electronic devices (including the microscope) may produce a spark which could ignite the lens cleaning solution. Use these chemicals in a well-ventilated area.

2. Don't use organic solutions to wipe the surfaces of the other components. Please use a neutral detergent if necessary.

If the microscope is exposed to liquid during operation, power it off immediately and wipe it dry. Never disassemble the microscope, the performance may be affected or the instrument may become damaged.

3. Cover the microscope with a dust cover when it is not in use

2. COMPONENTS

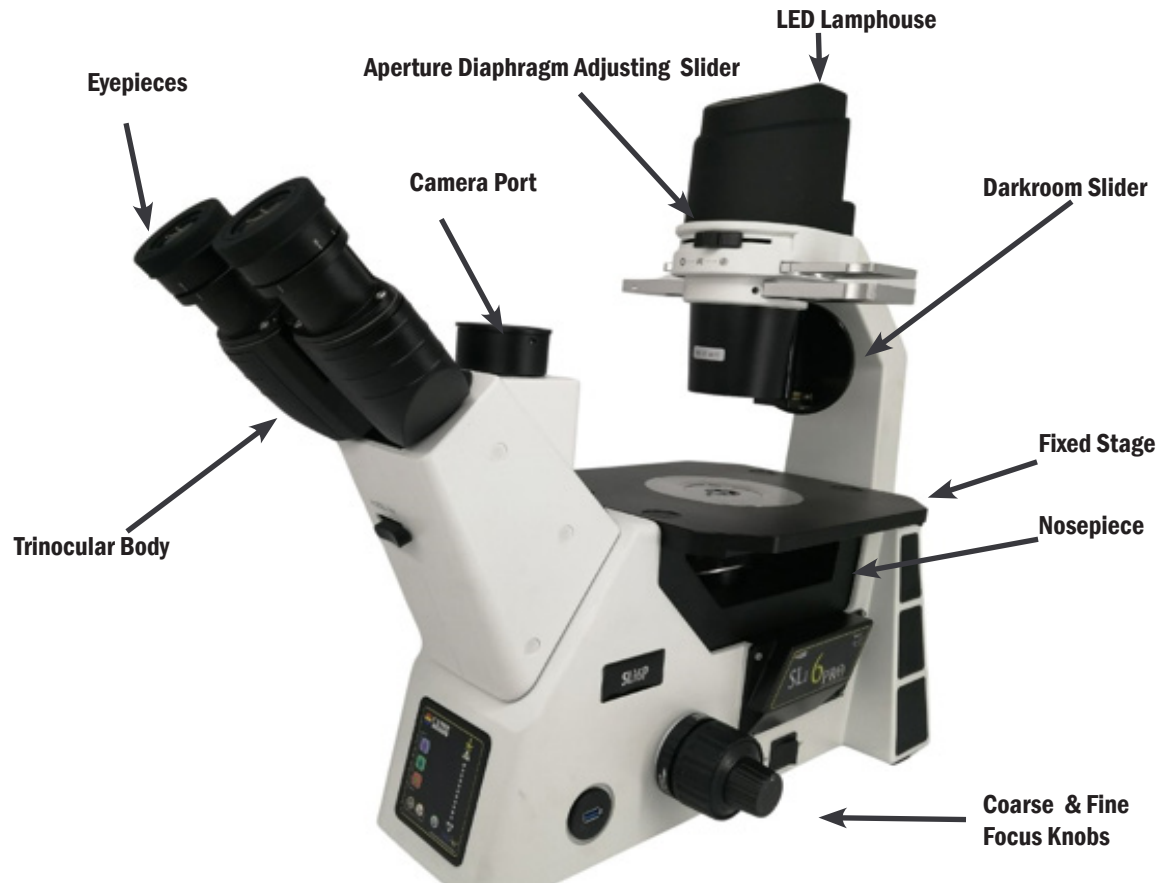

3-2-1 OBJECTIVE ASSEMBLY

1. Rotate the coarse focus knob, until the objective nosepiece is at the lowest position.
2. Install the objectives into the microscope nosepiece from the lowest magnification to the highest in a clockwise direction from the back of the microscope. Objectives can also be assembled by removing the metal/glass plate on the stage.
3. Search and focus the sample with a low magnification objective (4x or 10x), then change to the higher magnification objective if required.
4. Turn the nosepiece to switch between objectives. The objective is in position when you hear a “click.”

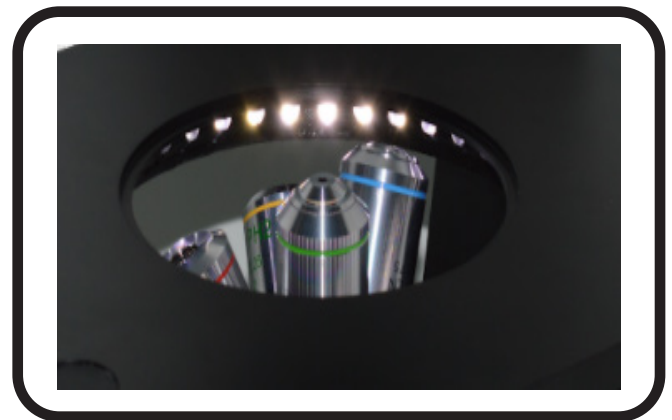
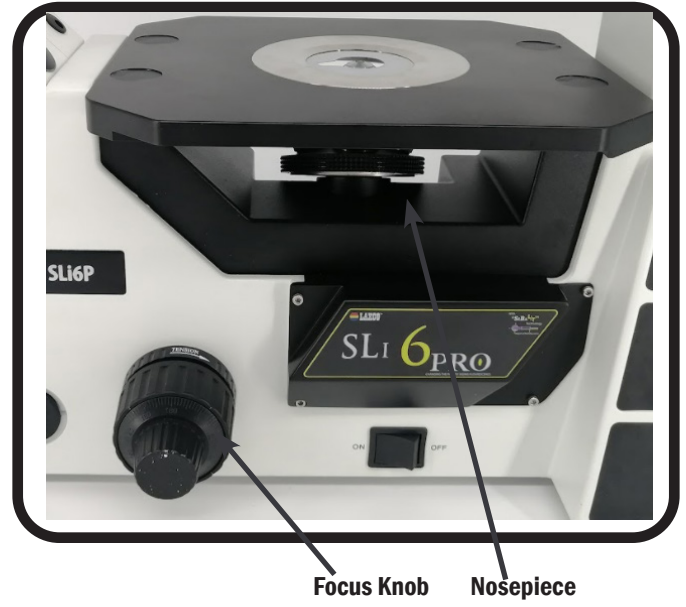

3-2-2 STAGE PLATE ASSEMBLY

1. Place the metal stage plate into the opening in the stage with the “V” facing the user. The glass stage plate allows the user to view which objective is being used.
2. Ensure that the stage plate is flush with the stage.

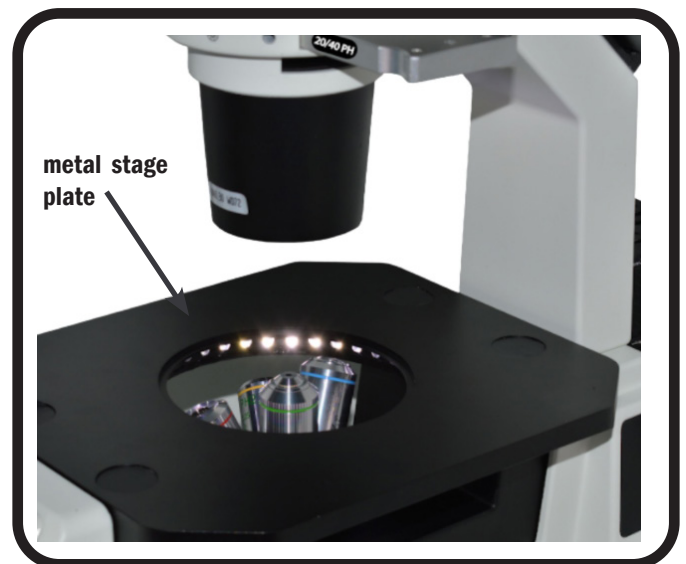

3-2-3 EYEPIECE ASSEMBLY

1. Remove the eyetube cover.
2. Insert the eyepiece into the eyetube.



3-2-4 PHASE - CONTRAST SLIDER ASSEMBLY

1. Place phase-contrast slider letter side up, into the holder from the right to the left.
2. To change setting, slide the correct phase ring into place. The phase ring is fully in position when you hear a "click".
3. Keep the aperture adjustment lever in the "o" position during phase-contrast observation.

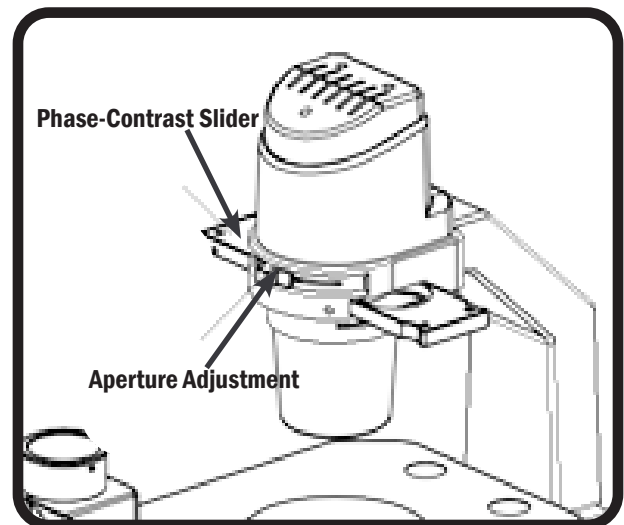

3-2-5 COLOR FILTER ASSEMBLY (FOR TRANSMITTED ILLUMINATION)

1. Turn the microscope off and allow the filter to cool before changing.
2. Slide out the filter holder and place the color filter in to the filter holder.
3. Ensure that the filter is flat and firmly pressed into the bottom of the filter holder.

*Filters can be stacked if needed, but the thickness must not exceed 11mm.

4. For fluorescence observation replace the color filter with the light barrier, in order to keep out the stray light.

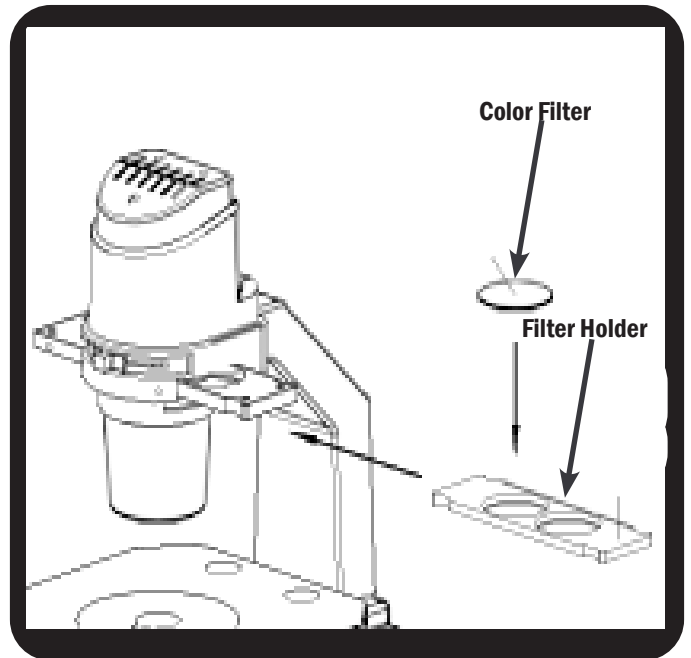

3-2-6 STAGE EXTENSION/ATTACHABLE MECHANICAL STAGE ASSEMBLY

The stage extension can be attached on both the left and right side of the stage to increase the stage size. The stage extension and the attachable mechanical stage both cannot be attached on the same side of the stage. For ease of use, it is recommended that the mechanical stage be attached to the right side of the stage and the stage extension be attached to the left side.

4. OPERATION

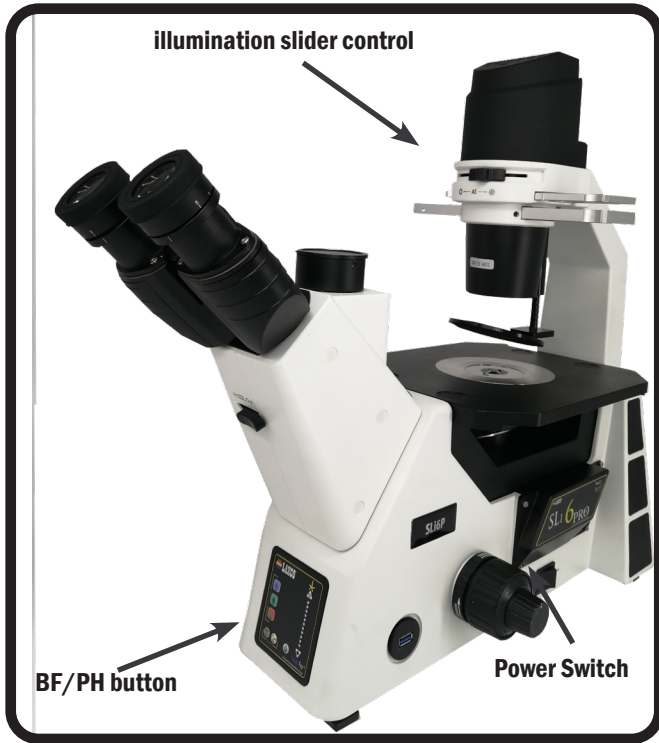

4-2 SPECIMEN PLACEMENT

1. Plug the microscope into a power outlet and turn the power switch to the ON position.
2. Press the BF/PH button located at the lower left on the membrane control panel on the front of the microscope body.
3. Use the illumination slider control to adjust brightness.
4. Move the slider control upwards to increase brightness, and downwards to reduce brightness. The illumination intensity setting is displayed on the front of the microscope.

4-2 SPECIMEN PLACEMENT

Place the sample in the center of the stage.

* Please select the vessel with a thickness of 1.2mm, Petri dish, culture flask etc., for best observation. Select specimen slide with the thickness of 1.2mm when the sample is placed on it.

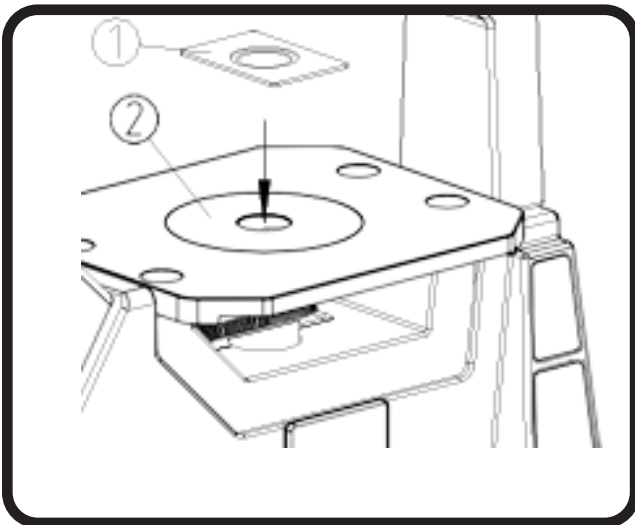

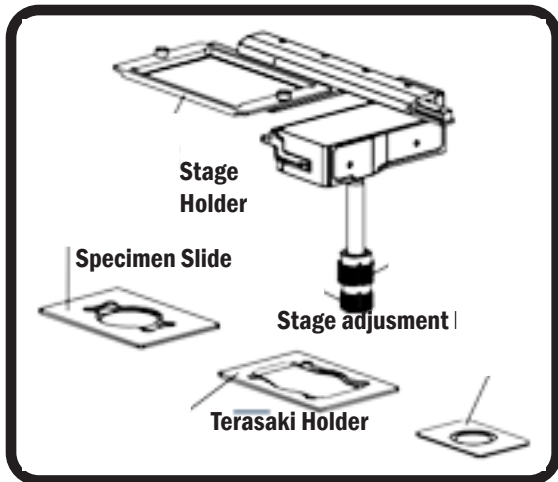

Operation of the attachable mechanical stage

1. Place the multi-well plate on the mechanical stage holder (4) when using 96 or 24 well plate.
2. Vessel Holders:
 - Terasaki holder for Terasaki plates.
 - $\phi 35\text{mm}$ vessel holder for $\phi 35\text{mm}$ dish.
 - Specimen slide holder to for a $\phi 54$ vessel and specimen slide to move the specimen.
3. Rotate the x/y stage adjustment knobs

* Carefully change the objective. The objective may collide with the circular central stage or the Petri dish holder when it is changed after utilizing shorter working distance objective. * Make sure to take off the circular stage plate from the fixed stage when use the mechanical stage if using shorter working distance objectives.



4-3 FOCUS ADJUSTMENT

1. Place a specimen on the circular stage plate, and then rotate the lowest mag objective into the light path.
2. View the specimen through the eyepieces and rotate the coarse focusing knob until the image is in focus
3. Rotate the fine focusing knob for a clearer image.

4-4 FOCUS TENSION ADJUSTMENT

If the coarse focus knob is difficult to rotate or the objective nosepiece “drifts” or loses focus this can typically be corrected by adjusting the focus tension.

Rotate the tension adjustment ring according to the arrow direction in the figure to tighten the focus tension; rotate the tension adjustment ring in the opposite direction to loosen the focusing system.

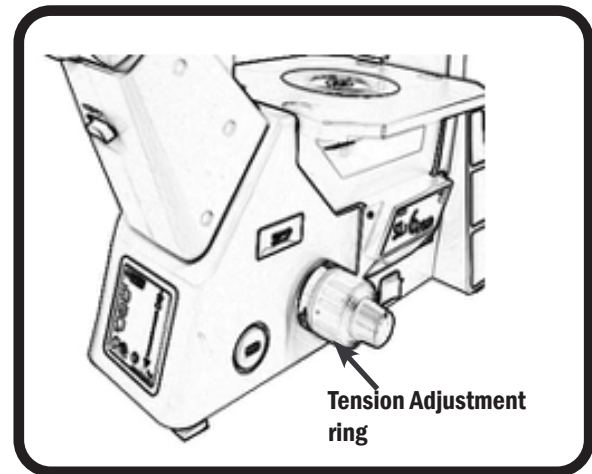

4-5 DIOPTRER ADJUSTMENT

1. Set the diopter on the eyepieces to “0”
2. Using your left eye, focus on a specimen using the coarse and fine focus knobs.
3. Once the image is clear using your left eye, look through the right eyepiece with your right eye and turn the diopter adjustment ring until the image is clear.

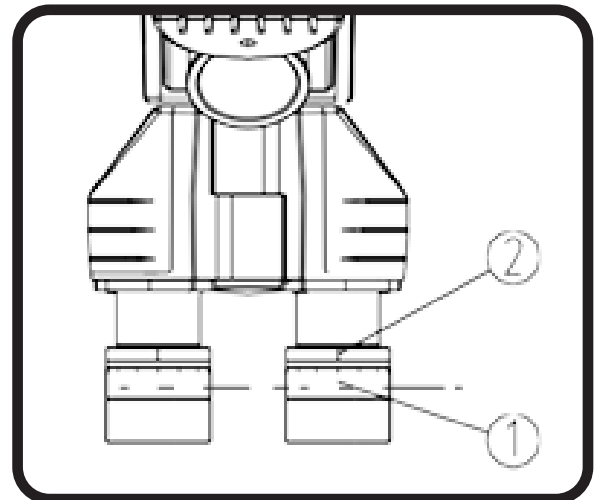

4-6 INTERPUPILLARY DISTANCE ADJUSTMENT

1. While looking through both eyepieces, move the eyepieces together or apart until the field appears as one circle and viewing is comfortable.
2. The number on the index (2) that lines up with the "." On the side (1) is the inter-pupillary distance of your eyes. Remember this number for future use.

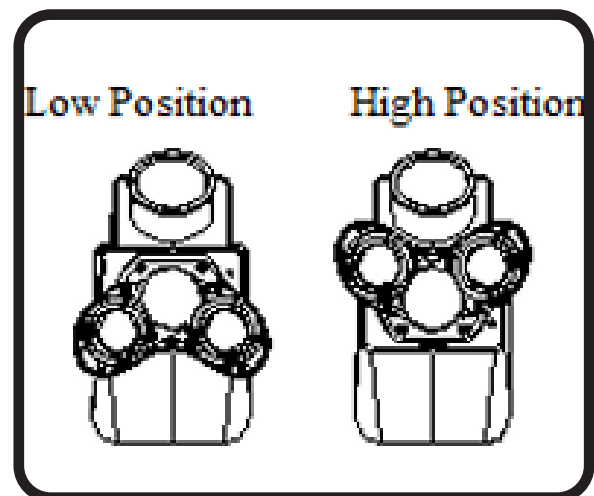
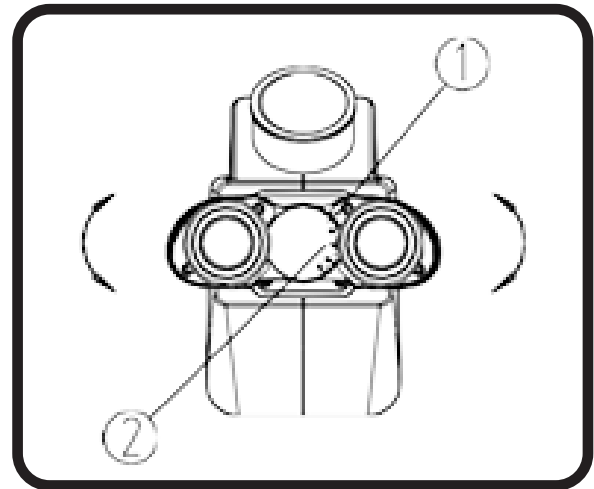

4-7 APERTURE DIAPHRAGM ADJUSTMENT

The aperture diaphragm determines the numerical aperture of the illumination in brightfield observation. If the N.A. of illumination matches the N.A. of the objective, you can obtain better resolution and contrast, and increase the depth of field.

Usually, adjust the N.A. to its 70%~80% when observing the stained specimen. Adjust the aperture diaphragm to "specimen." when observing finely detailed

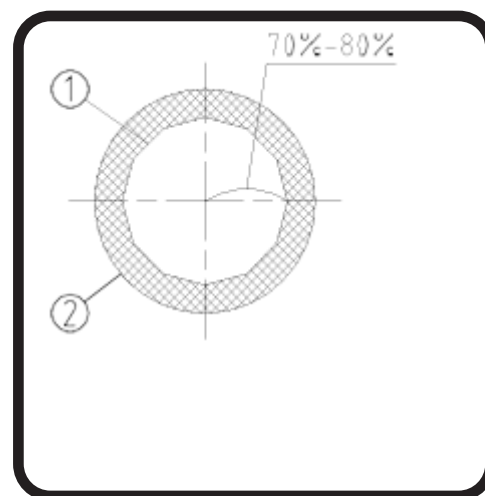

4-8 USE THE EYE-CAP

1. If the user wears glasses, turn the eyecup downward to prevent the glasses from touching the eyepiece and avoid damage to the glasses and the eyepiece.
2. Raise the eyecup for users without glasses. In this mode, the eyecup can prevent unwanted outside light.

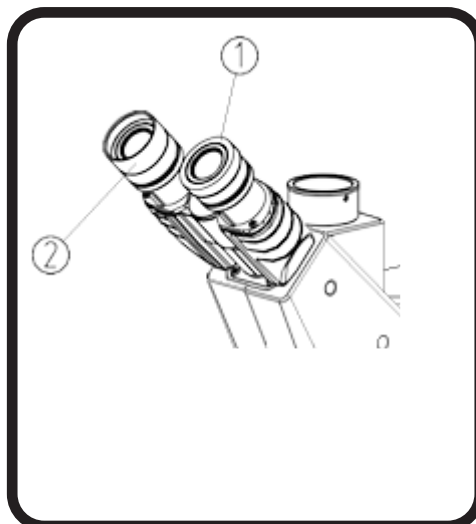

Use a colored filter to increase your visual acuity. It is suggested to use the LBD color filter to get more neutral color when observing brightfield



COLOR FILTER	PURPOSE
IF550	Monochromatic contrast color filter (green) (used in phase-contrast observation)
LBD	Color temperature transition color filter (used in brightfield observation)

4-10 CONDENSER LENS REMOVAL

The condenser lens can be removed to view specimens in large vessels, or cell stacks (up to 5 layers). Unscrew the condenser lens (1) to increase the working distance

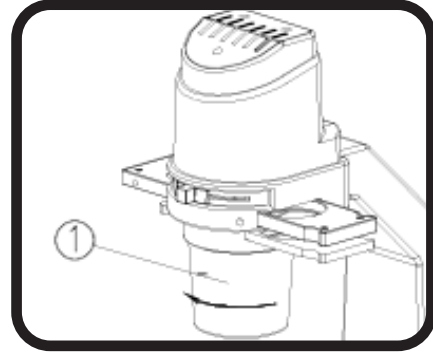

4-11 Enhanced Darkfield Contrast Illumination

The ring of LEDs for Darkfield Contrast are located below the fixed stage aperture, and provide illumination at an oblique angle to help find a focal plane and region of interest before switching to Fluorescence Illumination. Darkfield Contrast may be combined with Fluorescence to create a visual overlay.

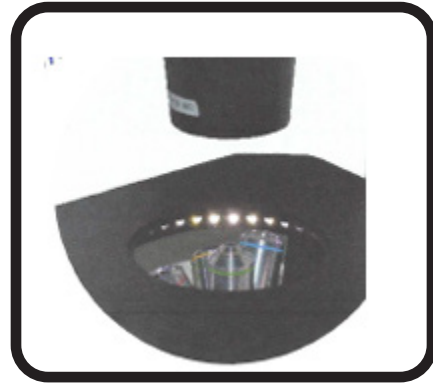

4-12 Multi-Illumination Contrast™ (MIC)

By actuating the MIC button located on the lower center of the membrane control panel; the user may select any combination of Illumination Modes, from Brightfield, Phase Contrast, Enhanced Dark Contrast, plus the Fluorescence Channels, either individually, or combined to allow the maximization of specimen details.

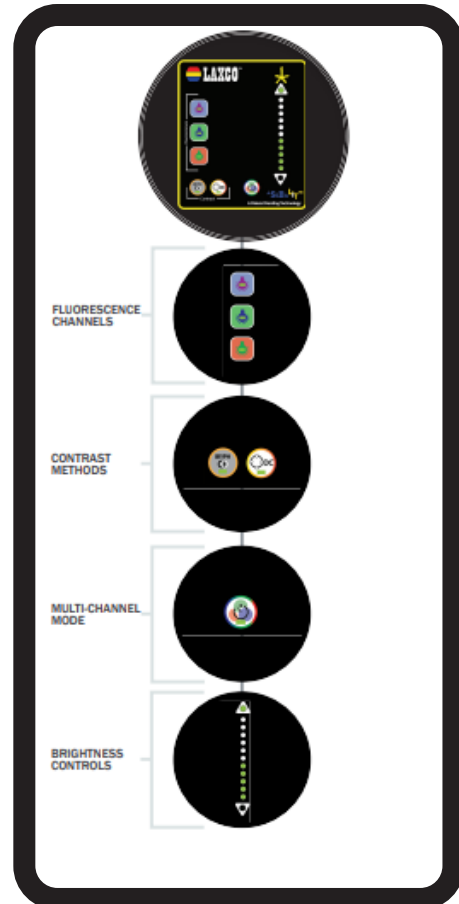



Light Shield

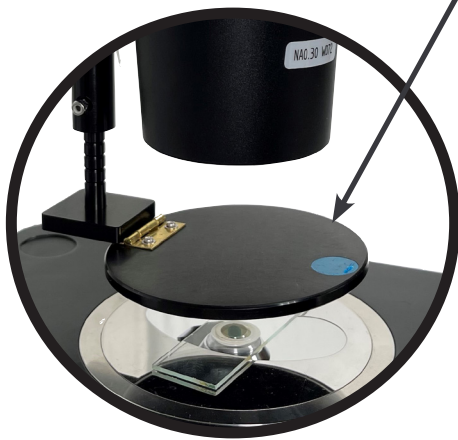

4-13 DARKROOM LIGHT SHIELD

The Darkroom Light Shield may be utilized to block extraneous room light while using the SLI6P in Fluorescence Mode.

The shield, located behind the condenser may be lowered and rotated close to the vessel, well plate, or slide to improve the Fluorescence signal to noise ratio.

4-14 Installing the Fluorescence Illumination / Filter Module

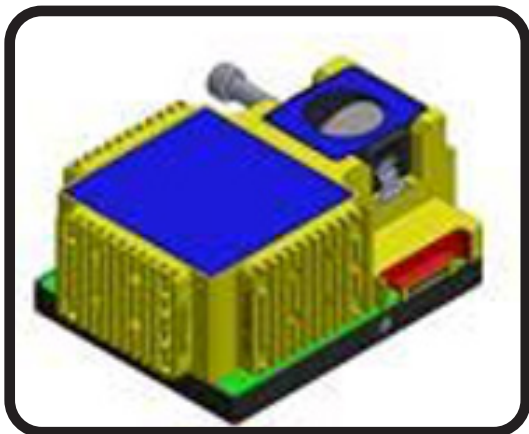

Select the desired Illumination/Filter Module and grasping the knurled knob, engage the dovetail slider with the matching slot inside the SLI6P body, until firmly set, then tighten the knurled knob in a clockwise direction. [The LED portion will be to the right, and the filter cube will be directly beneath the nose-piece].

4-15 OPERATING THE FLURESCENCE LEDs ON SLI6P CONTROL PANEL

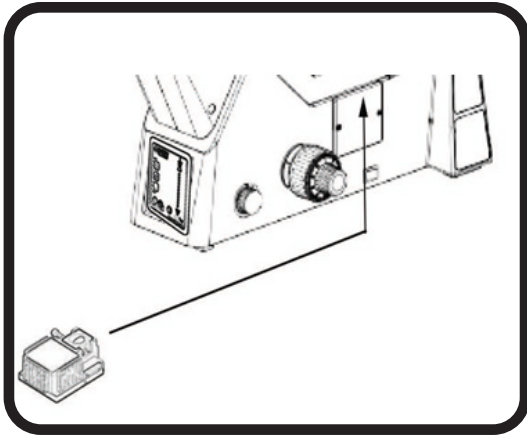

1. Select the desired LED from the Membrane Touch Panel, and press the button. Once for ON, Once again for OFF.
2. Adjust the intensity using the slider on the right hand side of the panel.
3. Add additional Channels by selecting the proper excitation LED(s)
4. For Multi-Illumination Contrast, the BrightField /Phase Contrast button and / or the Enhanced DarkField Contrast button(s) may be actuated and controlled by the same intensity slider.
5. Each individual channel may be controlled separately by selecting the channel and adjusting the intensity slider. Selecting another channel does not change the intensity of the previous channel.

5. CAMERA INSTALLATION



5.1 CAMERA INSTALLATION

Select the appropriate c-mount adapter.
(Note: c-mounts and cameras are optional equipment, and not included on all SLI6P systems).

1. Remove the dust cover plate (2) from the Trinocular Head Camera Port (1), by loosening the hex screw on the right side.
2. Select the c-mount and remove the threaded dust plug.
3. Remove the dust plug from the camera lens aperture (4), and thread the c-mount into the camera body in a clockwise direction.
4. Insert the camera / c-mount assembly into the Trinocular head with the label facing the operator and tighten the hex screw with the provided wrench.
5. Insert the power cord and USB cable in the appropriate sockets on the camera and then connect to the matching sockets on the Trinocular Body. 6. Install the SeBaLIT™ Software on the Tablet or Computer. 7. Refer to Software Manual for further reference

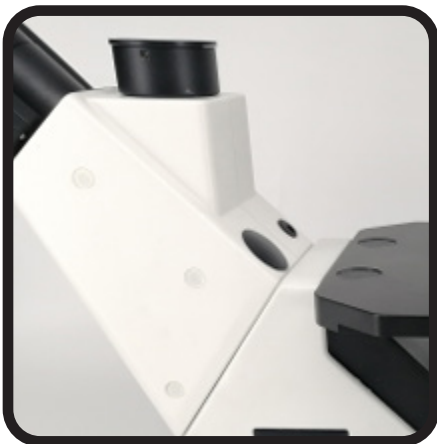
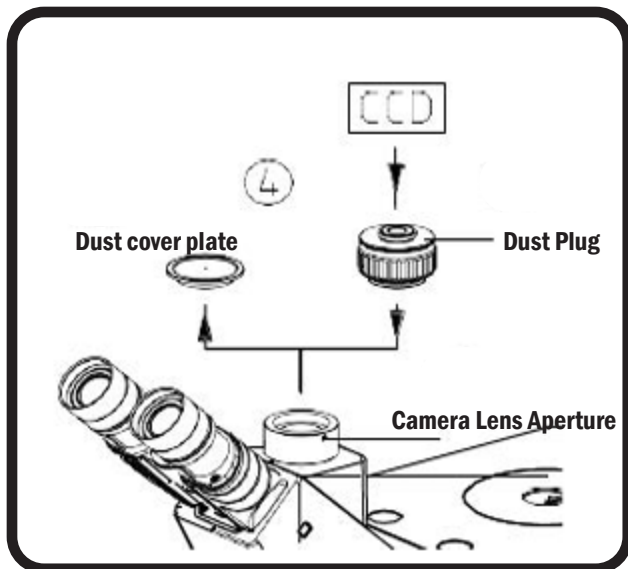

Power Port DC 12V,3A USB 3.0 Port (USB3.1 GEN1)

5. SPECIFICATION

SLI6P INVERTED MICROSCOPE SPECIFICATIONS

OPTICAL SYSTEM	Infinity corrected
HEAD	Trinocular - 45° inclined, rotatable; 360 degrees, Trinocular head, interpupillary distance 50mm-75mm, light splitting ratio 100:100.
OBJECTIVE	Infinity plan positive phase contrast objectives (4x, 10x, 20x 40x,), optional Infinity, Plan Fluorite objectives in Brightfield and positive phase contrast
EYEPIECE	2each, High eye point wide field plan eyepieces PL-10X with 22mm field of view, and adjustable diopters; with eyecups
FOCUS RANGE	Coarse and Fine - low position coaxial focusing mechanism, coarse range: 25mm; fine, precision: 0.002mm, with tension adjustment and upper limit stop
CONDENSER	N.A.0.3, working distance 72mm. Condensor lens may be removed to view specimens in large vessels or cell stacks (>5 high)

**FLUORESCENCE
ILLUMINATION AND
FLUORESCENCE FILTERS**

Excitation:
Variable intensity 10W LED: 410 nm for DAPI excitation
Variable Intensity 10W LED: 480-485nm for TRITC/mRFP
excitation

Excitation:

- 455nm +/-25nm for DAPI
- 525nm +/- 18nm for FITC/eGFP
- 605nm +/- 17.5nm for TRITC/mRFP

Dichronic Mirrors

Triple bandpass for DAPI, FITC, TRITC

**TRANSMITTED
ILLUMINATION**

**5w LED, Built-in. Pre-Centered, with continuous
intensity control.**

STAGES

**Fixed Stage Standard; (optional) attachable mechanical
x-y axis stage, moving range 120mm X 85mm, with metal
and glass plate inserts.**

NONEPIECE

Reversed quintuple

NOTE: Specifications and appearances are subject to change without any notice or obligation on the part of the manufacturer.

5. TROUBLESHOOTING

As the performance of microscope can't play fully due to unfamiliar operations, the table below can provide some solutions.

OPTICAL SYSTEM

PROBLEM	CAUSE	SOLUTION	REFERENCE PAGE
The LED light is bright, but it's dark in the field of view	- The LED is burned out	- Replace it with new one	9
	- The light adjusting slider control is too low	- Adjust it correctly	10
	- Image directed to camera port	- Move Slider to eyepiece position	13
The side of the field of the view is dark or not even	- The nosepiece is not in the right position	- Turn the nosepiece into the right position until you hear a click	7
	- The color filter and the slider are placed incorrectly	- Shift the filter slider until you hear a click	8
	- The phase-contrast slider is placed incorrectly	- Shift the phase slider until you hear a click	8
Direct or dust is observed in the field of view	- Direct has accumulated on the specimen	- Change or clean the specimen	-
	- Direct or dust has accumulated on the eyepieces	- Clean the eyepieces	-

OPTICAL SYSTEM

PROBLEM	CAUSE	SOLUTION	REFERENCE PAGE
Some parts of the image is not in the focal plane	- Objectives is not place in the light path	- Loosen it a little	8
	- The sample is place on the state incorrectly		12
	- The vessel has a curbed bottom		-
The eyes feel tired easily. The right field of view doesn't overlay with the left	- Interpupillary distance is wrong	- Tighten it a little	15
	- Diopter adjustment is wrong		14
	- Eyes not accustomed to binocular		-

MECHANICAL SYSTEM

PROBLEM	CAUSE	SOLUTION	REFERENCE PAGE
Coarse focusing knob can't move easily	- Coarse tension adjust ring is too tight	- Loosen it a little	14
The image is drifting out of focus	- Coarse tension adjust ring is too loose	- Tighten it a little	14

ELECTRICIAL SYSTEM

PROBLEM	CAUSE	SOLUTION	REFERENCE PAGE
The LED does not work	- No power supply	- Check the connection of power cord	5
	- The LED is burned out	- Replace it	11
The LED burns out quickly	- The wrong LED is used	- Replace it with the correct one	11
The field of view is now bright enough	- A wrong LED is used	- Replace it with a correct one	11
	- The light adjusting slider is faulty or improperly adjusted	- Adjust it correctly, or have serviced	12
The LED flickers or flashes	- The LED will fail soon	- Replace it with a new one	11
	- The light adjusting slider is faulty or improperly adjusted	- Connect it correctly	12

LED FLUORESCENCE ASSEMBLY

PROBLEM	CAUSE	SOLOUTION	REFERENCE PAGE
The Fluorescence LEDs have low intensity	- The Fluorescence LED Module is not turned on	- Turn on the Fluorence LEDs with the individual selection buttons on the from membrace panel, and ajdust intensity slider	14
	- The Multi-Illustration contrast button needs to be actuated	- Turn on the Multi-Illumination contrast button, select filter(s) and adjust intensity with slider switch	14
	- Unplugged Power Supply	- Check the connection of the powers supply cabel	9
	- The power cable us broken	- Replace the power cable	9
The LED for the selected channel is lit but visual field is dim	- The intensity control slider is not adjusted property	- Use the intensity slider control to achieve proper brightness - Unse darkroom light shield to eliminate stray light	15
For transmission bright field observation, the background is colored	- The Multi-Illustrations contrast button is actuated	- Press the MIC button to remove the Fluorescence channels from the transmitted image. Remove darkroom light shield from the optical path	15

8. CUSTOMER AND TECHNICAL SERVICE

RETURNED GOODS POLICY

For Repair or Replacement Parts

To return goods for repair or replacement, please contact LAXCO Inc. Customer Service by one of the numbers above. Please be prepared to supply the following information:

- Your name, return shipping address and telephone number
- Catalog/Model number of the item(s) you are returning
- Serial Number(s), if applicable
- Description of the product's problem or reason for the return
- Date the item was purchased
- Distributor information, if applicable

A Laxco representative will issue you a Return Materials Authorization (RMA) number. Please label the outside of your shipping container with the RMA number.

Microscope Packing Instructions

For more details on using specific controls, refer to the "Operation: Controls and Adjustments" section. Whenever possible, ship the microscope in its original packaging. If the original packaging is not available, use appropriate shipping materials, including a heavy cardboard box and plenty of cushioning foam.

1. Wedge a block of foam between the objectives and the stage to protect lenses from impact.
2. Tighten the condenser lock screw and remove the sliders.
3. Wedge a block of foam between the fixed stage and the nosepiece / objectives.
4. Remove the mechanical stage (if attached).
5. Pack with a minimum of 3 inches all the way around the microscope. Use enough packing material to ensure the microscope will not shift within the box.
6. Tape the box securely and label the outside with your RMA number. Do not return the microscope before calling LAXCO Customer Service for authorization.

IMPORTANT! Improperly packaged will be insurable. Verify your order requirements before packing and shipping

1. For digital models, pack the camera separately.
2. Wrap the eyepieces with a plastic bag, secured with a rubber band at the base of the eyetubes.
3. Set the objective turret to the lowest magnification.
4. Use the coarse focus knob to lower the nosepiece all the way to the bottom of its travel range.

9. REFERENCE

Key Concepts

MAGNIFICATION

Magnification increases the apparent size of an object you are viewing through the microscope.

Magnification by itself does not provide more information about an object unless there is also adequate resolution and contrast. The objective lens and oculars (eyepieces) determine magnification.

Magnification = eyepiece value X objective lens value

RESOLUTION

Resolution is the ability to distinguish small objects that are close together. Resolution becomes more difficult as objects become smaller and closer together. At some point, the objects will “fuse” together and become indistinguishable. This point is the resolution limit of the microscope.

CONTRAST

Contrast of an object relative to the background is also necessary in order to resolve it. Without adequate contrast, it is impossible to distinguish an object from its background even when magnification and resolution are adequate.

Resolution and Contrast are largely dependent upon specimen illumination. This involves using the illuminator (lamp), field iris, condenser iris, and objective lens. Optimal lighting for most specimens is achieved through Koehler illumination (page 9). Collector lens filters may also enhance image quality.

FIELD OF VIEW

The actual diameter of the observable field in the sample varies with the field number of the eyepiece and the magnification of the objective. It can be calculated by dividing the field number of the eyepiece by the magnification of the objective.

Example:

For an 18 mm field number eyepiece and a 10x objective, $FOV = 18 \text{ mm}/10 = 1.8 \text{ mm}$ field of view

Glossary of Microscopy Terms

A

Abbe Condenser: A simple condenser comprised of two lenses; corrects for chromatic aberration.

Aberration: Term used to describe any inaccuracy in focusing of light; derived from physical limitations of lenses and optics.

Aberration Chromatic: Inaccurate focusing of red, green and blue light.

Aberration Spherical: Inaccurate focusing of light due to curvature of lens surface.

Achromat: A classification of microscope objectives with simpler lenses corrected for chromatic aberration by bringing red and blue light to the same point of focus.

Aplanatic Achromatic: A term describing the level of optical correction; typically used for condensers. This term indicates that the optical device is corrected to produce a flat field (aplanatic) as well as to accurately focus red, green, and blue light (achromatic).

B

Beam Splitter: An optical device that divides the incoming light beam. The beam can be divided either in terms of wavelength (for example, reflecting shorter wavelengths but transmitting longer wavelengths) or partial reflection (for example, from a partially mirrored surface or at the angled surface of a prism).

C

C-mount: A type of camera adapter typically used to connect video cameras to a microscope.

CCD: Type of video camera using electronic chips as the detector. CCD stands for charged-coupled device. Light falling on the chip creates an electrical charge at a specific location.

Centering Telescope: A special eyepiece fitted with a focusing mechanism and a longer-than-usual focal length, used for observing the back focal plane of an objective. The centering telescope can be used for aligning components for phase contrast.

Concave: Referring to a lens surface; bowing inward.

Condenser: The optical component located nearest the specimen but between the specimen and the light source; responsible for the placement and angle of light approaching the specimen.

Contrast: Visibility of an object or feature against its background. **Convex:** Referring to the curve of a lens surface; bowing outward.

Coverslip Thickness: The thickness of a piece of glass used to protect and contain the sample on the slide. This value, usually 0.17 mm, is an optical requirement of the microscope, usually engraved on the barrel of the objective.

Glossary of Microscopy Terms

D

Depth of Field: The vertical distance in the sample through which features are simultaneously in focus. High numerical aperture objectives have a “shallow depth of field” and image only a very thin slice of information from the specimen.

Diffraction: Bending of light at the edges of features.

Diopter Setting: The focus of one eyepiece with respect to the other to compensate for differences in focus between the microscopist’s eyes. A critical setting to avoid eyestrain and headaches.

E

Eyepiece: The optical component that provides the second step in magnification.

Eyepoint: The back focal plane of the eyepiece; the location at which the cornea of the eye is placed so that the information from the microscope can be imaged on the retina of your eye.

Eyepoint, High: A special optical design in which the eyepoint is raised about 18 mm above the top surface to accommodate people who wear eyeglasses.

F

Field Aperture: The opening controlling the diameter of the field to be illuminated. The opening is controlled by an iris called a field iris.

Field Curvature: One of the optical distortions. When the center of the image is in focus and the edges the field is said to “have curvature.” When the image is in focus from the center to the edges, the field is said to be “flat.” Plan objectives are corrected to produce flat fields.

Field Number: A number, usually engraved on an eyepiece, referring to the diameter of a baffle or raised ring inside the eyepiece. Determines the viewing field for the eyepiece. See also “Field of View.”

Field of View (FOV): The actual diameter of the observable field in the sample; varies with the field number of the eyepiece, magnification of the objective and other intervening optics.

Filter: A device that changes either the intensity or the wavelength of light interacting with it.

Flatfield: See “Field Curvature.”

Focal Length: Distance between the optical center of a lens and the point at which it will focus light coming from infinity.

Focal Plane: An imaginary, two-dimensional plane at right angles to the optic axis, comprised of an infinite number of focal points. Since an image can only be formed when light comes to a focus, the focal plane can be thought of as an imaginary “screen” on which the image is formed.

Glossary of Microscopy Terms

H

High Eyepoint: A design characteristic of eyepieces in which the back focal plane of the eyepiece is raised about 18 mm above the top of the eyepiece to accommodate microscopists who wear glasses.

I

Illumination, Axial: A contrast-enhancement technique for improving edge contrast. The condenser is closed most of the way, producing a highly coherent cylinder of light.

background light scattering when it hits the edge of the phase plate.

Image: The focusing of light in an organized fashion to reproduce information collected from the object. The more accurately the light is focused, the more accurately the object is represented in the image.

Illumination, Phase Contrast: A contrast-enhancement technique used to image phase objects. Using a specifically designed annulus or ring placed at the front focal plane of the condenser, the zero-order background light is carefully placed into a special optical device (phase plate), mounted in the back focal plane of the objective. The phase plate has two functions: it reduces the intensity of the background light to approximately 15% of its original value and decreases its phase by one quarter of a wavelength.

The light passing through a well-behaved phase-altering specimen (such as a cell) slows down by a quarter wave on that interaction, then another quarter-wave as it passes through the thickest part of the phase plate. As a result, when it meets the background light at the primary imaging plane, it is a half-wave out of step. The resulting destructive interference enhances contrast, making the object more visible against the background. Phase images often suffer from bright haloes at the edge of fine detail, partially due to the

Image Analysis: Any type of measurement performed on the image, ranging from particle sizing and counting to determinations of motility or field-specific parameters such as orientation.

Immersion Medium: The material used between the uppermost surface of the sample and the objective. The immersion medium could be air, water, immersion oil, etc.

In Phase: A relationship between waves of light. When waves are “in phase,” they must be coherent (come from the same source, have the same wavelength, travel in the same direction, at the same point in time, vibrating in the same plane) and will reach their peak and fall to their trough at the same time. They are, literally, in step with each other. Phase annuli must be centered to produce in-phase images.

Glossary of Microscopy Terms

Infinity Corrected Optics: A special optical design involving at least two lenses in which the object is placed at the focal plane of the first lens, causing the imaging rays to emerge parallel to the optic axis or some principal ray. Since the emerging rays never focus to make an image, they are said to be carrying that information to “infinity.” The second lens then picks up the information as sets of parallel rays, and brings them into focus at its back focal plane. In a microscope, the objective is the first lens, the telan lens is the second.

Interpupillary Distance: The physical distance between centers of the pupils in the microscopist’s eyes; usually measured in millimeters.

Iris, Condenser: Iris controlling the angle at which light emerges from the condenser and approaches the sample; located at the front of the focal plane of the condenser.

Iris, Field: Iris controlling the size of the illuminated field in the sample. Usually located around the light port. Reducing the size of the field iris is one technique for controlling haze and glare.

K

Koehler Illumination: An approach to microscope alignment that separates the illuminating set planes from an imaging set. A major goal of this approach is to illuminate evenly the back focal plane of the objective for maximum resolution and evenly illuminated background.

L

Light, Polarized: Light in which the waves vibrate in only one direction, perpendicular to the direction of travel.

Long Working Distance (LWD): A term used for specially designed objectives and condensers providing more clearance between the surface near the sample and the sample itself. Especially useful for tissue culture and microtitre work.

M

Magnification: A mathematical relationship between the size of an image and the size of the original object. If the image is larger than the object, the term used is “magnification”; if the image is smaller than the object, the term used is “minification.”

Micron: A unit of length measurement. A micron (or micrometer) is 10^{-6} meters (0.000001 meters) or about $1/25,000$ of an inch.

Microscopy: The art and science of making fine detail visible. The four major issues in microscopy today are magnification, resolution, contrast and measurement

Microscope, Compound: A microscope providing magnification in two stages, the first through the objective and the second through the eyepiece.

Microscope, Inverted: A standard microscope configuration in which the sample is viewed from below. Especially useful when working with very thick samples such as tissue cultures and microtitre plates.

Glossary of Microscopy Terms

Microscope, Stereo: A standard microscope configuration based on two independent imaging paths, separated by approximately 10-12 degrees, resulting in a stereoscopic image characterized by great three-dimensionality and great depth of field. Frequently uses lower power (0.5 to 300x total magnification). and for setting the limit of resolution for the entire system.

Microscope, Upright: A standard microscope configuration in which the sample sits face up on a stage, with the objectives mounted above it.

Microscopy: The art and science of making fine detail visible. The four major issues in microscopy today are magnification, resolution, contrast and measurement.

N

Neutral-Density Filter: An amplitude object; an object that absorbs all colors of light equally.

Numerical Aperture (N.A.): A measure of information-collecting ability of a microscope optic. The numerical aperture is a product of the sine of half of the collecting angle and the refractive index of the immersion material. The greater the N.A., the better the resolving ability.

P

Phase: A property of light in which waves are “in step” with each other. See also “In phase.”

Phase Contrast: A contrast-enhancement technique that detects phase objects. It uses a special ring, placed in the condenser to control location of the undiffracted light, and a matching phase plate, placed in the back focal plane of the objective. A wellbehaved phase sample will slow light by approximately one-quarter of a wavelength compared to the undiffracted background light. The phase plate is especially engineered to slow the diffracted light another quarter-wave. When the undiffracted light meets the diffracted light at the primary imaging plane to form the image, they will be out of step with each other by a half-wave, creating the condition of destructive interference and resulting in the darkening of the phase object and an improvement in contrast. Phase kits include a green filter (usually about 546 nm), which defines the wavelength for which the kit is optimized.

Photo Adapter: A special tube enabling cameras to be attached to the microscope.

Pixel: An electronic term used to describe the points of information used to map an image on a TV screen or computer monitor. Literally, a picture (“pix”) element (“el”). Each pixel carries at least the x,y location in the map and an intensity value (based on 256 gray levels).

Plan: An optical correction for objectives and condensers, indicating that the optical component has been corrected to produce a flat viewing field.

Glossary of Microscopy Terms

Primary Image: The first magnified image formed in the microscope.

Primary Image Plane: The location of the first magnified image formed by the objective

R

Refraction: Bending of light as it passes, at an angle, across a boundary between materials of different refractive index; governed by Snell's Law.

Refractive Index (n or n_i): A number describing the relationship between the velocity of light in a material of interest compared to the velocity of light in a vacuum or air. The slower the velocity in the material, the higher the refractive index.

Resolution (R): The smallest distance by which two objects can be separated and still be imaged as two independent objects.

Reticle: A small disk with an engraved or photographic pattern such as a ruler or grid, placed in the eyepiece, in the primary image plane, so that the pattern will superimpose on the image of the specimen. Used for measurement (length, angle, counting, etc.).

S

Snell's Law: The law governing refraction, relating to angles of approach and exit as light passes, at an angle, from one material to a second material of different refractive index. Snell's Law states that light will bend toward the normal (an imaginary reference line drawn perpendicular to the surface at the point of entrance) as it passes from lower to higher refractive index

Trinocular Port: A special eyepiece, usually narrower in design than conventional eyepieces, used in the photo tube of the microscope to project a real image to the film plane or detector of a camera system.

Tube Length, Fixed: An optical design approach in which the object is placed at some distance in front of the objective, causing the image to focus at a specific distance behind the objective. Typical distances for the mechanical tube length in these systems are either 160 mm or 170 mm.

Tube Length, Mechanical: The distance from the objective shoulder to the seat of the eyepiece. When replacing objectives, the mechanical tube lengths must match.

Tube Length, Optical: The distance between the back focal plane of the objective and the primary image plane.

Tube Lens: In infinity corrected optics, a lens that works along with the objective to form the image at the primary image plane. See also "Telan lens."

W

Wavelength: The distance along a wave from peak to peak or trough to trough. In microscopy, wavelength is often correlated to the color and energy of light.

White light: Light containing all three primary colors: red + green + blue.



LAXCO, Inc.
18303 Bothell-Everett Hwy
Suite 140
Mill Creek, WA 98012
www.SeBaMicro.com
www.laxcoinc.com

Contact us:
For customer service: 425-686-3081, option 1
For service support: 425-686-3081, option 2
For technical support: 425-686-3081, option 3

1700074(1) - User Manual SLi6 Pro Inverted Fluorescent Microscope