



# LMI6000 Inverted Microscope



Version 2.0

# User Manual

# CONTENTS

1.	Components .	5
2.	Assembly	8
	Assembly Schematic .	9
	Assembly Steps .	
3.	Operation	12
	Set Illumination, Transmission Illumination	12
	Specimen Placement	12
	Focus Adjustment	13
	Focus Tension Adjustment	13
	Interpupillary Distance Adjustmen	14
	Aperture Diaphragm Adjustment	15
	Eyecups	15
	Color Filter	15
	Condenser Lens Removal	16
4.	Assemble and Use the Accessories	17
	Phase-contrast Assembly and Use	17
	C-Mount Assembly .	18
5.	Troubleshooting	19
6.	Reference	23

## Before Use

# 1. Operation Notice

### Environmental Concerns

1. Place the microscope on a level flat surface where vibration from other pieces of equipment will not occur.
2. Windows should have adjustable coverings to vary the amount of sunlight directed to the work area
3. Place microscope facing away from windows.

### Special Precautions

1. Always carry the microscope with one hand supporting the base (1) and the other hand around the stand (2)
- \* It will damage the microscope by holding the stage, focusing knob, head or light source.**
4. Ensure there is enough room for the heat dissipation around the light source housing.
  5. Fluorescence microscopy should be performed in dark environment. In order to protect eyes, do not stare at fluorescence light directly.
  6. Before replacing the transmitted LED, always turn the power switch to the "OFF" position and disconnect the power cord.

**\* Bulb: Transmitted lighting: Single 5W LED (class 3B)**



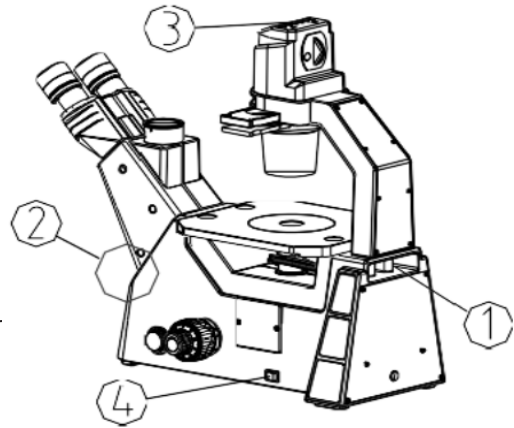

7. Only use the external power supply included with the microscope.



# 2. Maintenance

1. Wipe the lens gently with a soft lens tissue. Carefully wipe off oil or finger prints with tissue moistened with alcohol or lens cleaning solution.
2. Do not use organic solution to wipe the surface of other components. Please use the neutral detergent if necessary.
3. If the microscope is exposed to liquid, turn off the power immediately and wipe it dry.

### 3. Safety Sign

SIGN	SIGNIFICATION
	Surface may be hot
	Refer to instructions before use. Improper operation would lead to person hurt or instrument failure.
	Main switch ON
	Main switch OFF

# 1. Components

## LMI6000 Biological Microscope (Phase Contrast)



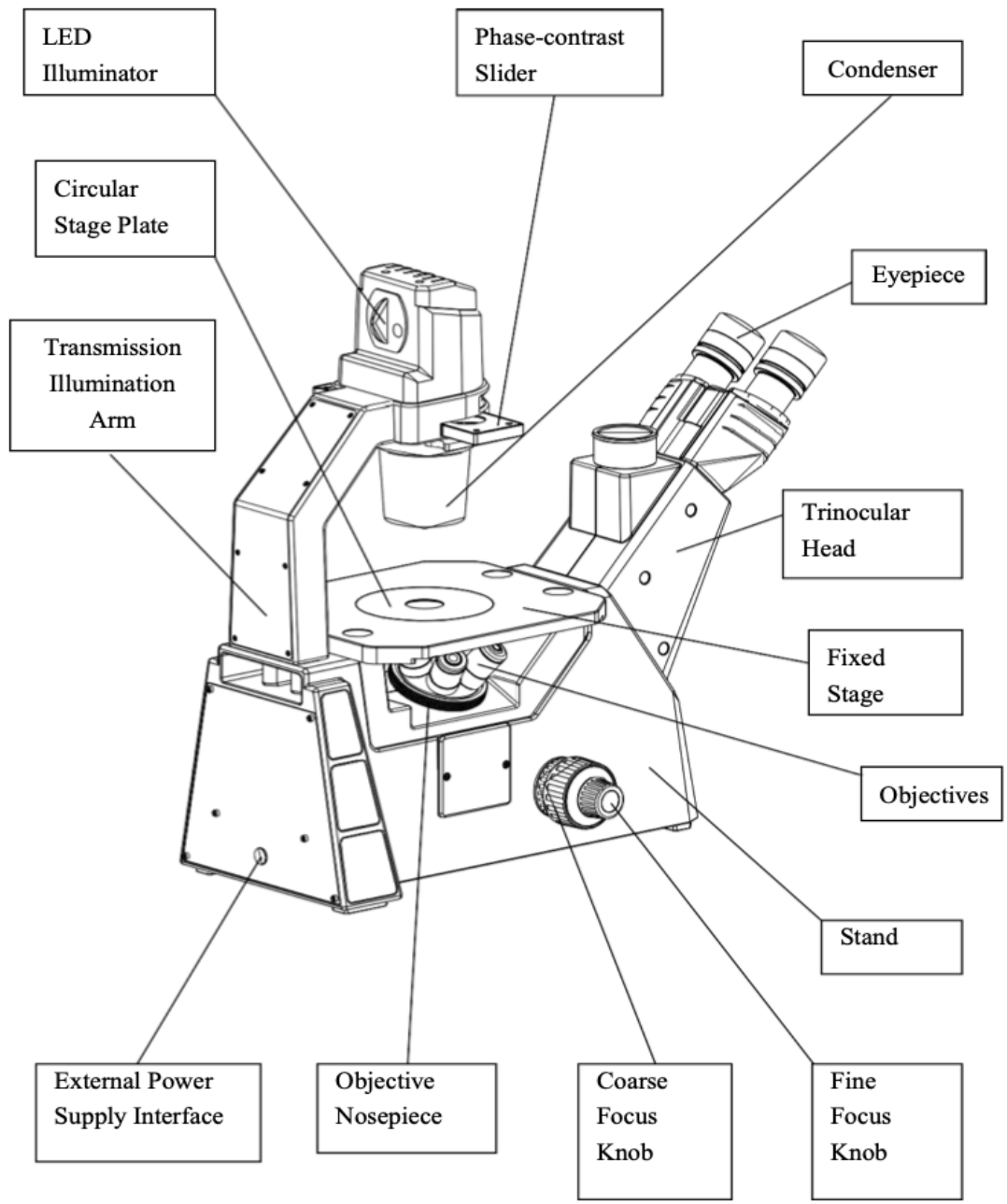

## LMI6000 Biological Microscope (LED Fluorescence Model)

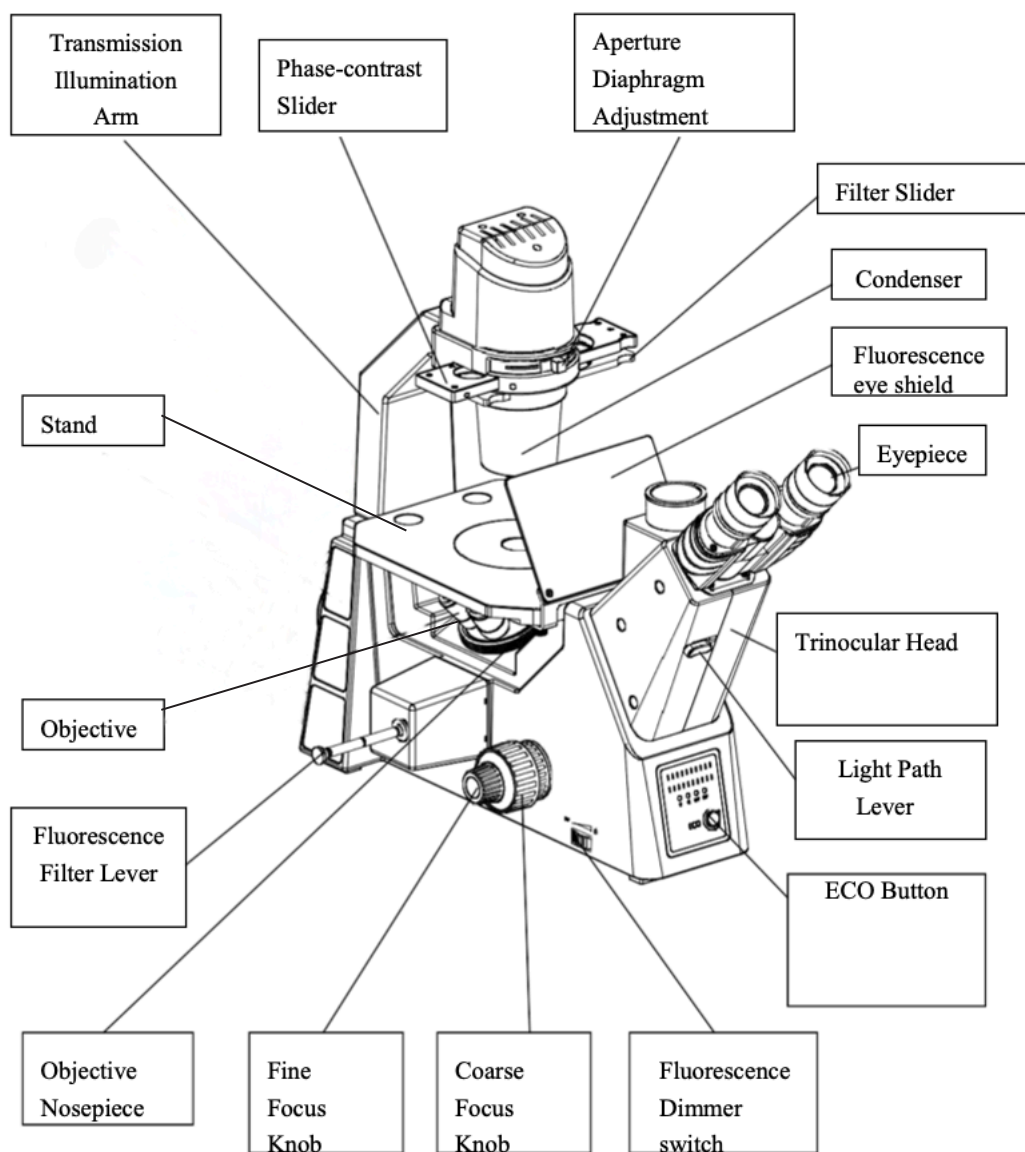

## 2. Assembly

### 2-1 Assembly Schematic

Below is the Assembly Schematic to describe how to assemble the components. The numbers denote the assembly order.

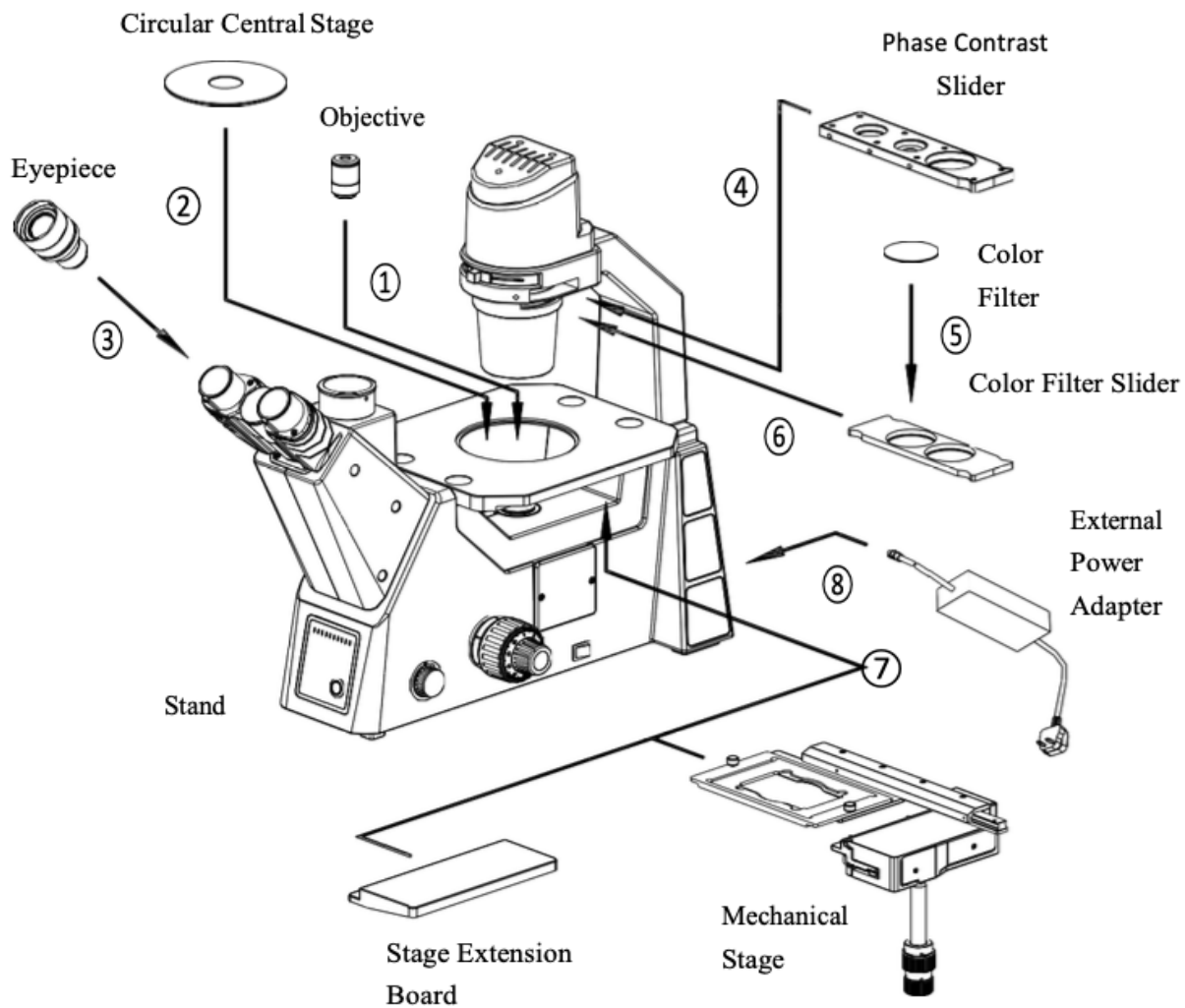



## 2-2 Assembly Steps

### 2-2-1 Objective Assembly

- (1) Rotate the coarse focus knob (1), until the objective nosepiece is at the lowest position.
- (2) Install the objectives into the microscope nosepiece from the lowest magnification to the highest in a clockwise direction from the back of the microscope. Objectives can also be assembled by removing the metal/glass plate on the stage.
- (3) Search and focus the sample with a low magnification objective (4x or 10x), then change to the higher magnification objective if required.
- (4) Turn the nosepiece to switch between objectives. The objective is in position when you hear a “click.”

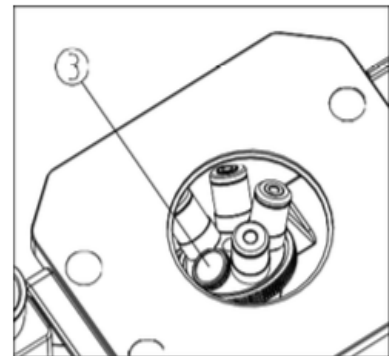
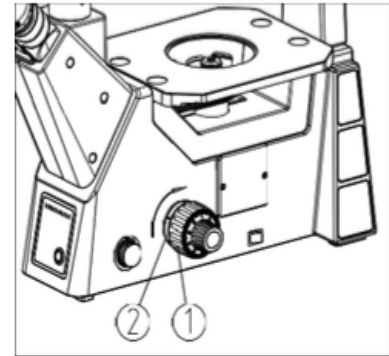

### 2-2-2 Stage Plate Assembly

- (1) Place the metal stage plate (1) into the opening in the stage with the “V” (2) facing the user. The glass stage plate allows the user to view which objective is being used.
- (2) Ensure that the stage plate is flush with the stage.

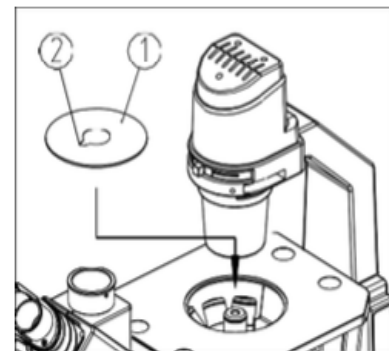

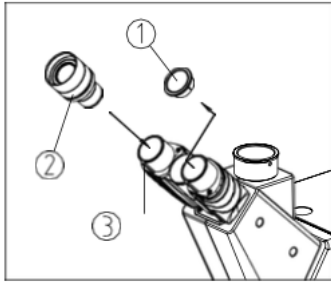

### 2-2-3 Eyepiece Assembly

1. Remove the eyetube cover (1).
2. Insert the eyepiece (2) into the eyetube.

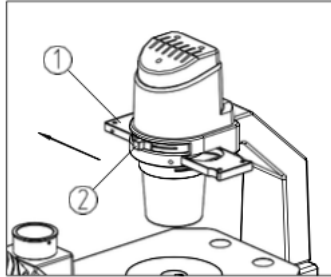

### 2-2-4 Phase-contrast Slider Assembly

1. Place phase-contrast slider (1) letter side up, into the holder from the right to the left.
2. To change setting, slide the correct phase ring into place. The phase ring is fully in position when you hear a "click".
3. Keep the aperture adjustment lever (2) in the "o" position during phase-contrast observation.

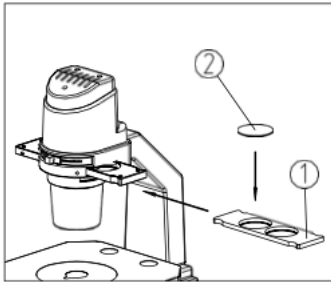

### 2-2-5 Color Filter Assembly (For Transmitted Illumination)

1. Turn the microscope off and allow the filter to cool before changing.
2. Slide out the filter holder (1), and place the color filter (2) in to the filter holder.
3. Ensure that the filter is flat and firmly pressed into the bottom of the filter holder.

**\* Filters can be stacked if needed, but the thickness must not exceed 11mm.**

4. For fluorescence observation replace the color filter with the light barrier, in order to keep out the stray light.

### 2-2-6 Stage Extension / Attachable Mechanical Stage Assembly

The stage extension can be attached on both the left and right side of the stage to increase the stage size. The stage extension and the attachable mechanical stage both cannot be attached on the same side of the stage. For ease of use, it is recommended that the mechanical stage be attached to the right side of the stage and the stage extension be attached to the left side.

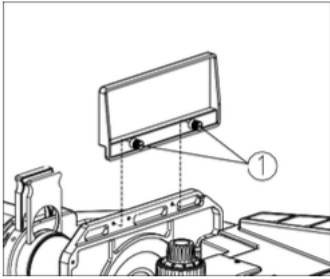

**Attach the stage extension or mechanical stage as follows:**

- (1) Screw the lock-screws (1) into the bottom of the stage extension or mech. stage.
- (2) Screw it into the bottom of the stage.

### 2-2-7 Power Cord

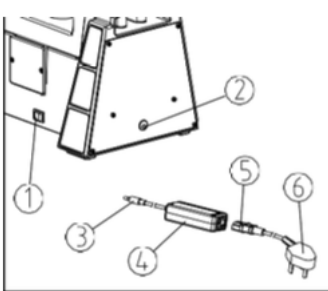

- (1) Turn the power switch (1) to the “o” OFF position before connecting the power cord.
- (2) Insert the plug (3) into the external power supply (4) into the outlet on the back of the microscope (2).
- (3) Insert the power plug (5) into the power supply (4).
- (4) Insert the 3-prong plug (6) into a grounded outlet.

### 2-2-8 Replacing the Bulb

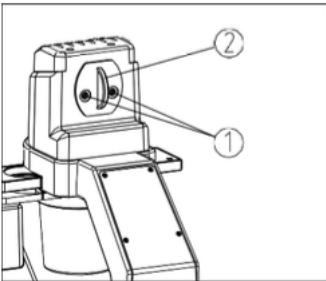

- (1) Remove the screws (2) with allen wrench.
- (2) Remove the LED module (2).
- (3) Gently insert new LED module to avoid damage.
- (4) Replace screws (2).
- (5) Connect the power cord, and turn the On/Off switch to the “on” position.

**\* Before attempting to replace or remove the LED, unplug the microscope from all power sources, turn the power switch to the “off” position and allow the LED to cool completely.**

# 3. Operation

## Set Illumination (Transmitted Illumination)

1. Plug the microscope into a power outlet and turn the power switch (1) to the ON position.
2. Use the illumination dimmer control (2) to adjust brightness.
3. Turn the dimmer clockwise to increase brightness, and counter-clockwise to reduce brightness. The illumination setting is displayed on the front of the microscope.
4. Press the ECO button (4) to activate the energy saving function of the microscope. If the microscope is not used for 30 minutes the light source will automatically turn off. To turn off the ECO function, press the button (4) again.

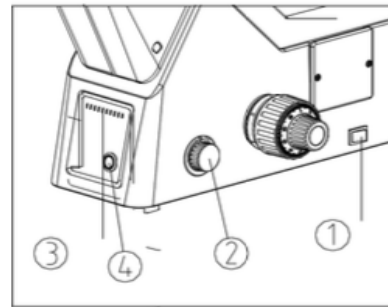

## 3-2 Specimen Placement

Place the sample in the center of the stage.

- \* Please select the vessel with a thickness of 1.2mm, Petri dish, culture flask etc., for best observation. Select specimen slide with the thickness of 1.2mm when the sample is placed on it.

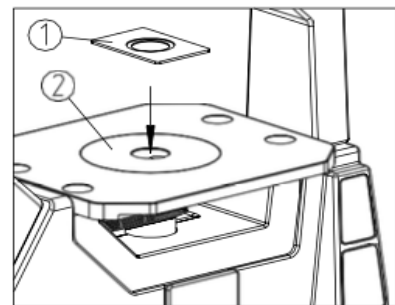

## Operation of attachable mechanical stage

1. Place the multi-well plate on the mechanical stage holder (4) when using 96 or 24 well plate.
2. Vessel Holders:
  - Terasaki holder (2) for Terasaki board.
  - 35mm petri dish holder (1) for 35mm petri dish.
  - Specimen slide holder (3) to for a 54 petri dish and specimen slide.
3. Rotate the x/y stage adjustment knobs to move the specimen.

\* Carefully change the objective. The objective may collide with the circular central stage or the Petri dish holder when it is changed after observing with shorter working distance objective.

\* Make sure to take off the circular stage plate of the stage when use the mechanical moving stage.

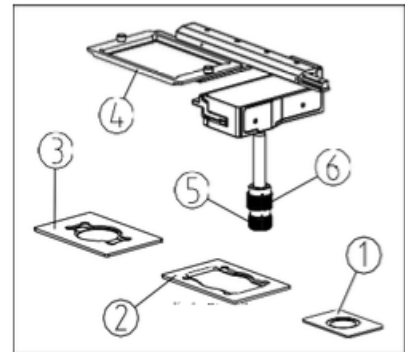

### 3-3 Focus Adjustment

1. Put a specimen on the circular central stage, and then shift the lowest mag. Objective (4X or 10X) into the light path.
2. View the specimen through the eyepieces and rotate the coarse focusing knob (1) until the image is in focus
3. Rotate the fine focusing knob (2) for clear details.

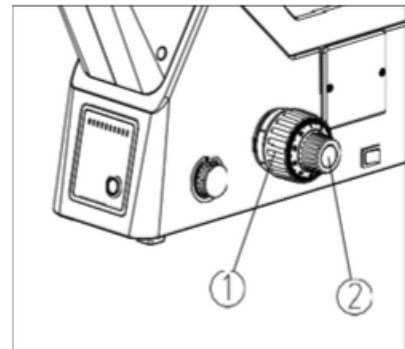

### 3-4 Focus Tension Adjustment

If the coarse focus knob is difficult to rotate or the objective nosepiece “drifts” or loses focus this can typically be corrected by adjusting the focus tension.

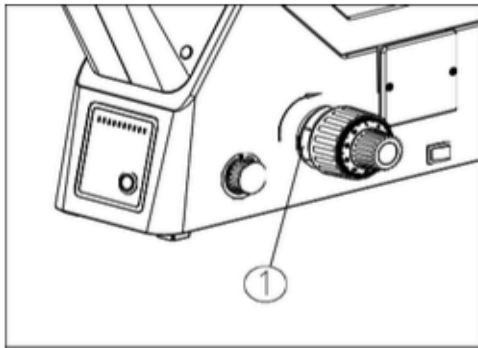

Rotate the tension adjustment ring (1) according to the arrow direction in the figure to tighten the focus tension; rotate the tension adjustment ring in the opposite direction to loosen the focusing system.

### 3-5 Diopter Adjustment

1. Set the diopter on the eyepieces to "0"
2. Using your left eye, focus on a specimen using the coarse and fine focus knobs.
3. Once the image is clear using your left eye, look through the right eyepiece with your right eye and turn the diopter adjustment ring (1) until the image is clear.

**\* There is a  $\pm 5$  diopter on the diopter adjustment ring. The number on the scale (1) that aligns with the "I" (2) on eyepiece base is your eye's diopter. Keep this index number for future reference.**

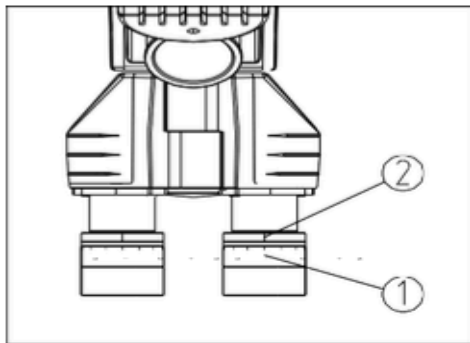

### 3-6 Interpupillary Distance Adjustment

1. While looking through both eyepieces, move the eyepieces together or apart until the field appears as one circle and viewing is comfortable.
2. The number on the index (2) that lines up with the "." on the side (1) is the interpupillary distance of your eyes. Keep this index for future use.

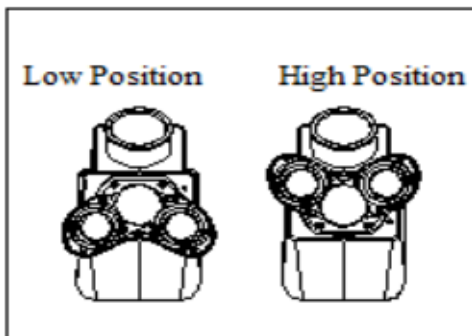
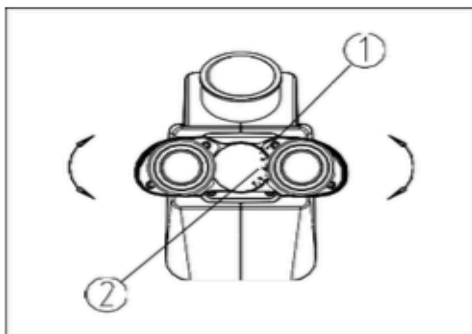

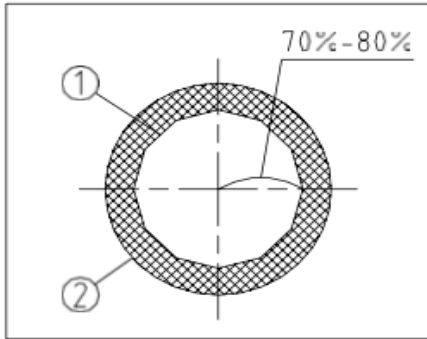

### 3-7 Aperture Diaphragm Adjustment

The aperture diaphragm determines the numerical aperture of the illumination in brightfield observation. If the N.A. of illumination matches the N.A. of the objective, you can obtain better resolution and contrast, and increase the depth of field. Usually, adjust the N.A. to its 70%~80% when observing the dyed specimen. Adjust the aperture diaphragm to “ ” when observing the bacteria specimen.

### 3-8 Use the Eye-cap

1. If the user wears glasses, turn the eyecup inward to prevent the glasses from touching the eyepiece and avoid damage to the glasses and the eyepiece.
2. Open the eyecup (2) for users without glasses. In this mode, the eyecup can prevent unwanted outside light.

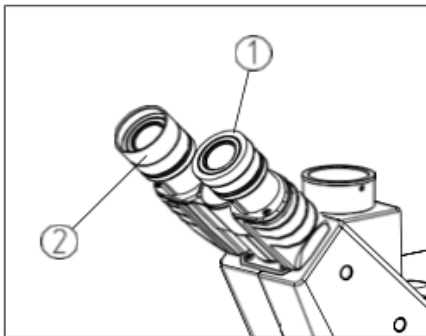

### 3-9 Color Filter

Use a color filter to increase the accuracy of the observation. It is suggested to use the LBD color filter to get more neutral color when observing brightfield

- \* Insert color filter according to 2-2-5

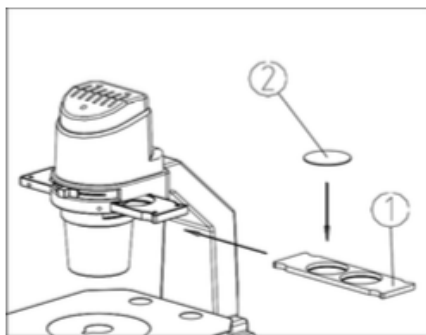

### 3-10 Condenser Lens Removal

The condenser lens can be removed to view specimens in large vessels. Unscrew the condenser lens (1) to increase the working distance

Color filter	Purpose
IF550	Monochromatic contrast color filter (green) (used in phase-contrast observation)
LBD	Color temperature transition color filter (used in brightfield observation )

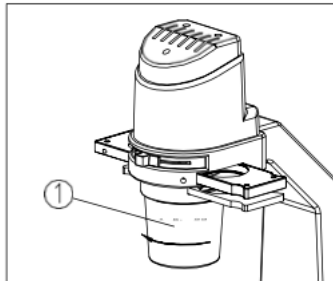



## 4. Installation and Use of Accessories

### 4-1 Phase-contrast Assembly and Use

#### 4-1-1 Phase-contrast Objective

1. Magnification of Phase-contrast Objective: 4X, 10X, 20X, 40X.
2. Replace the objective of nosepiece with the phase-contrast objective, and assemble it as 2-2-1.

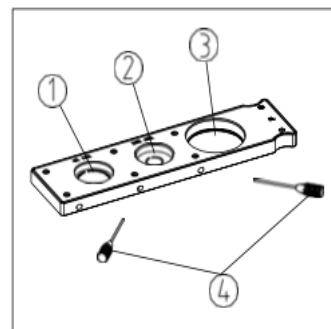

#### 4-1-2 Phase-contrast Slider

Phase center adjustable slider

1. Phase ring for use with 4x and 10x phase contrast objectives.
2. Phase ring for 20x and 40x phase contrast objectives.
3. Open position for brightfield observation.
4. Phase ring alignment tools.

#### 4-1-3 Centering the Phase Contrast Annuli

1. Place specimen on the stage and focus it.
2. Remove the eyepiece, and replace it with CT (centering telescope), insert it into the tube without diopter adjustment.
3. Make sure the matched phase ring (in the phase-contrast objective) and the light ring (in the phase-contrast slider) are in the light path.
4. Loosen the lock screw of the centering telescope and observe into the centering telescope when pulling the upper part of it to focus the phase ring (2) of the focusing objective. Screw down the lock screw when it is in clear focus.

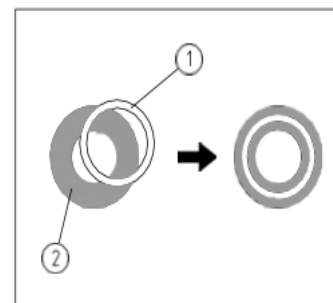

5. Insert the alignment tools (4) into two holes (3) in the phase-contrast slider, and then adjust them until the phase rings are aligned over each other.
6. Repeat steps for all phase ring/objective combinations.

**\* If the phase rings are not centered, the user will not achieve optimal phase-contrast observation.**

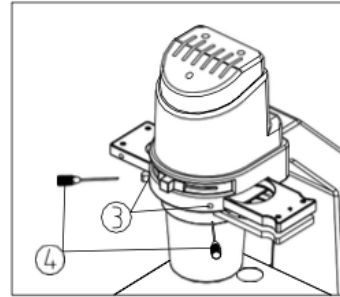

### 5-2-1 C-mount Assembly

1. Loosen the lock-screw (1) on the trinocular head and remove the dust-cover (2).
2. Remove the dust-cover caps of the c-mount adapter (3) and the camera. Insert the screw thread end of c-mount adapter onto the camera, and then install the c-mount into the camera port.
3. Tighten down the lock-screw.
4. During observation if the image displayed by the camera is not in parfocal with the eyepieces, adjust the focus ring on the camera adapter until the image is in focus.

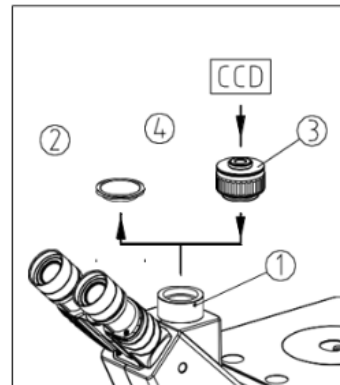

## 5. Troubleshooting

As the performance of microscope can't play fully due to unfamiliar operations, the table below can provide some solutions.

Problem	Cause	Solution	Reference Page
<b>Optical System</b>			
The LED light is bright, but it's dark in the field of view.	The LED is burn out	Replace it with new one	
	The light adjusting knob is too low.	Adjust it correctly.	
	A wrong bulb is used.	Replace it with a correct one.	
The side of the field of the view is dark or not even.	The nosepiece is not in the right position	Turn the nosepiece into the right position until hearing a click	
	The color filter and the flashboard placed incorrectly	Shift the flashboard until hearing a click.	
	The phase-contrast slide placed incorrectly	Shift the slide until hearing a click.	
Stain or dust is observed in the field of view.	Stains have accumulated on the specimen	Change the specimen	
	Stains have accumulated on the eyepieces	Clean the eyepieces	

Problem	Cause	Solution	Reference Page
About the resolution <ul style="list-style-type: none"> <li>• Unclear image</li> <li>• phase-contrast is out of work</li> <li>• Unclear image of fine structure</li> </ul>	Objectives is not placed in the light path correctly	Turn the nosepiece into the right position until hearing a click	
	The aperture diaphragm opened incorrectly	Adjust the aperture diaphragm	
	Stain or dust has accumulated on the condenser, objective, eyepieces, or specimen vessel	Clean it	
	The thickness of specimen slide or Petri dish is not 1.2mm	Use the one with thickness of 1.2mm	
	Use bright-field objective	Change it with phase-contrast objective	
	The light loop of phase-contrast slide is unmatched with the phase ring	Use the light loop matched with phase ring	
	The light loop and the phase ring are not centered	Center them correctly	
	The light loop and the phase ring are deviate when observing the edge of the Petri dish	Move the Petri dish to get the best phase contrast effect	

Problem	Cause	Solution	Reference Page
Some parts of image is not in the focal plane	Objectives is not place in the light path	Turn the nosepiece into the right position until hearing a click	
	The specimen placed on the stage incorrectly	Place the specimen correctly	
	The optical effect of the Petri dish is not good (ex: bottom smooth)	Use the dish with smooth surface	
The eyes feel tired easily. The right field of view doesn't overlay with the left.	Interpupillary distance is wrong	Adjust the interpupillary distance	
	Diopter adjustment is wrong	Adjust the diopter	
	Eyes not accustomed to binocular observation	Do not goggle at the specimen when observing. Observe the entire field of view or look something else before observing.	
<b>Mechanical System</b>			
Coarse focusing knob can't move easily	Coarse tension adjust ring is too tight	Loosen a little	
The image is not in the focal plane when observing	Coarse tension adjust ring is too loose	Tighten a little	

Problem	Cause	Solution	Reference Page
<b>Electrical System</b>			
The bulb does not work	No power supply	Check the connection of the power cord	
	The bulb is burnt out	Replace it	
The bulb burns out usually.	A wrong bulb is used	Replace it with a correct one.	
The field of view is not bright enough.	A wrong bulb is used.	Replace it with a correct one.	
	The use of light adjusting knob is wrong.	Adjust it correctly.	
The bulb flickers or the brightness is not stable	The bulb is burn out soon	Replace it with a new one	
	The wire doesn't connect well	Connect it correctly	

# 6. REFERENCE

## Glossary of Microscopy Terms

### A

**Abbe Condenser:** A simple condenser comprised of two lenses; corrects for chromatic aberration.

**Aberration:** Term used to describe any inaccuracy in focusing of light; derived from physical limitations of lenses and optics.

Aberration, Chromatic: Inaccurate focusing of red, green and blue light.

Aberration, Spherical: Inaccurate focusing of light due to curvature of lens surface.

**Achromat:** A classification of microscope objectives with simpler lenses corrected for chromatic aberration by bringing red and blue light to the same point of focus.

**Aplanatic Achromatic:** A term describing the level of optical correction; typically used for condensers. This term indicates that the optical device is corrected to produce a flat field (aplanatic) as well as to accurately focus red, green, and blue light (achromatic).

### B

**Beam Splitter:** An optical device that divides the incoming light beam. The beam can be divided either in terms of wavelength (for example, reflecting shorter wavelengths but transmitting longer wavelengths) or partial reflection (for example, from a partially mirrored surface or at the angled surface of a prism).

### C

**C-mount:** A type of camera adapter typically used to connect video cameras to a microscope.

**CCD:** Type of video camera using electronic chips as the detector. CCD stands for charged-coupled device. Light falling on the chip creates an electrical charge at a specific location.

**Centering Telescope:** A special eyepiece fitted with a focusing mechanism and a longer-than-usual focal length, used for observing the back focal plane of an objective. The centering telescope can be used for aligning components for phase contrast.

**Concave:** Referring to a lens surface; bowing inward.

**Condenser:** The optical component located nearest the specimen but between the specimen and the light source; responsible for the placement and angle of light approaching the specimen.

**Contrast:** Visibility of an object or feature against its background.

**Convex:** Referring to the curve of a lens surface; bowing outward.

**Coverslip Thickness:** The thickness of a piece of glass used to protect and contain the sample on the slide. This value, usually 0.17 mm, is an optical requirement of the microscope, usually engraved on the barrel of the objective.

### D

**Depth of Field:** The vertical distance in the sample through which features are simultaneously in focus. High numerical aperture objectives have a "shallow depth of field" and image only a very thin slice of information from the specimen.

**Diffraction:** Bending of light at the edges of features.

**Diopter Setting:** The focus of one eyepiece with respect to the other to compensate for differences in focus between the microscopist's eyes. A critical setting to avoid eyestrain and headaches.

# Glossary of Microscopy Terms

## E

**Eyepiece:** The optical component that provides the second step in magnification.

**Eyepoint:** The back focal plane of the eyepiece; the location at which the cornea of the eye is placed so that the information from the microscope can be imaged on the retina of your eye.

**Eyepoint,High:** A special optical design in which the eyepoint is raised about 18 mm above the top surface to accommodate people who wear eyeglasses.

## F

**Field Aperture:** The opening controlling the diameter of the field to be illuminated. The opening is controlled by an iris called a field iris.

**Field Curvature:** One of the optical distortions. When the center of the image is in focus and the edges fall out of focus, the field is said to “have curvature.” When the image is in focus from the center to the edges, the field is said to be “flat.” Plan objectives are corrected to produce flat fields.

**Field Number:** A number, usually engraved on an eyepiece, referring to the diameter of a baffle or raised ring inside the eyepiece. Determines the viewing field for the eyepiece. See also “Field of View.”

**Field of View (FOV):** The actual diameter of the observable field in the sample; varies with the field number of the eyepiece, magnification of the objective and other intervening optics.

**Filter:** A device that changes either the intensity or the wavelength of light interacting with it.

**Flatfield:** See “Field Curvature.”

**Focal Length:** Distance between the optical center of a lens and the point at which it will focus light coming from infinity.

**Focal Plane:** An imaginary, two-dimensional plane at right angles to the optic axis, comprised of an infinite number of focal points. Since an image can only be formed when light comes to a focus, the focal plane can be thought of as an imaginary “screen” on which the image is formed.

**Focal Point:** The point at which light comes to a focus to form an image. Lens systems have two major, on-axis focal points; one at the focal length, on the side of the lens from which the light is approaching (the front focal point), and the second at the focal length behind the lens (the back focal point). There are also an infinite number of focal points, both on-axis and off-axis, determined by the relevant placement of the object and the curvature and composition of the lens system.

**Field Aperture:** The opening controlling the diameter of the field to be illuminated. The opening is controlled by an iris called a field iris.

**Focus:** The ability of a lens to converge light waves to a single point.

**Focusing Eyepiece:** An eyepiece fitted with a mechanism for adjusting the space between its lenses and therefore for adjusting focus.

**Focusing Telescope:** See “Centering Telescope.”

**FOV:** See “Field of View.”

**Frame Grabber:** An electronic device that captures an image digitally.



# Glossary of Microscopy Terms

## H

**High Eyepoint:** A design characteristic of eyepieces in which the back focal plane of the eyepiece is raised about 18 mm above the top of the eyepiece to accommodate microscopists who wear glasses.

## I

**Illumination, Axial:** A contrast-enhancement technique for improving edge contrast. The condenser is closed most of the way, producing a highly coherent pencil of light.

**Illumination, Phase Contrast:** A contrast-enhancement technique used to image phase objects. Using a specifically designed annulus or ring placed at the front focal plane of the condenser, the zero-order background light is carefully placed into a special optical device (phase plate), mounted in the back focal plane of the objective. The phase plate has two functions: it reduces the intensity of the background light to approximately 15% of its original value and decreases its phase by one quarter of a wavelength. The light passing through a well-behaved phase-altering specimen (such as a cell) slows down by a quarter wave on that interaction, then another quarter-wave as it passes through the thickest part of the phase plate. As a result, when it meets the background light at the primary imaging plane, it is a half-wave out of step. The resulting destructive interference enhances contrast, making the object more visible against the background. Phase images often suffer from bright haloes at the edge of fine detail, partially due to the background light scattering when it hits the edge of the phase plate.

**Image:** The focusing of light in an organized fashion to reproduce information collected from the object. The more accurately the light is focused, the more accurately the object is represented in the image.

**Image Analysis:** Any type of measurement performed on the image, ranging from particle sizing and counting to determinations of motility or field-specific parameters such as orientation.

**Immersion Medium:** The material used between the uppermost surface of the sample and the objective. The immersion medium could be air, water, immersion oil, etc.

**In Phase:** A relationship between waves of light. When waves are “in phase,” they must be coherent (come from the same source, have the same wavelength, travel in the same direction, at the same point in time, vibrating in the same plane) and will reach their peak and fall to their trough at the same time. They are, literally, in step with each other. Phase annuli must be centered to produce in-phase images.

**Infinity Corrected Optics:** A special optical design involving at least two lenses in which the object is placed at the focal plane of the first lens, causing the imaging rays to emerge parallel to the optic axis or some principal ray. Since the emerging rays never focus to make an image, they are said to be carrying that information to “infinity.” The second lens then picks up the information as sets of parallel rays, and brings them into focus at its back focal plane. In a microscope, the objective is the first lens, the telan lens is the second.

**Interpupillary Distance:** The physical distance between centers of the pupils in the microscopist's eyes; usually measured in millimeters.

**Iris, Condenser:** Iris controlling the angle at which light emerges from the condenser and approaches the sample; located at the front of the focal plane of the condenser.

**Iris, Field:** Iris controlling the size of the illuminated field in the sample. Usually located around the light port. Reducing the size of the field iris is one technique for controlling haze and glare.

# Glossary of Microscopy Terms

## K

**Koehler Illumination:** An approach to microscope alignment that separates the illuminating set planes from an imaging set. A major goal of this approach is to illuminate evenly the back focal plane of the objective for maximum resolution and evenly illuminated background.

## L

**Light, Polarized:** Light in which the waves vibrate in only one direction, perpendicular to the direction of travel.

**Long Working Distance (LWD):** A term used for specially designed objectives and condensers providing more clearance between the surface near the sample and the sample itself. Especially useful for tissue culture and microtitre work.

## M

**Magnification:** A mathematical relationship between the size of an image and the size of the original object. If the image is larger than the object, the term used is "magnification"; if the image is smaller than the object, the term used is "minification."

**Micron:** A unit of length measurement. A micron (or micrometer) is  $10^{-6}$  meters (0.000001 meters) or about 1/25,000 of an inch.

**Microscope, Compound:** A microscope providing magnification in two stages, the first through the objective and the second through the eyepiece.

**Microscope, Inverted:** A standard microscope configuration in which the sample is viewed from below. Especially useful when working with very thick samples such as tissue cultures and microtitre plates.

**Microscope, Stereo:** A standard microscope configuration based on two independent imaging paths, separated by approximately 10-12 degrees, resulting in a stereoscopic image characterized by great three-dimensionality and great depth of field. Frequently uses lower power (0.5 to 300x total magnification).

**Microscope, Upright:** A standard microscope configuration in which the sample sits face up on a stage, with the objectives mounted above it.

**Microscopy:** The art and science of making fine detail visible. The four major issues in microscopy today are magnification, resolution, contrast and measurement.

## N

**Neutral-Density Filter:** An amplitude object; an object that absorbs all colors of light equally.

**Numerical Aperture (N.A.):** A measure of information-collecting ability of a microscope optic. The numerical aperture is a product of the sine of half of the collecting angle and the refractive index of the immersion material. The greater the N.A., the better the resolving ability.

## O

**Object:** The actual feature of interest or study under the microscope.

**Objective:** The optical component that gathers the information-bearing light from the specimen. Responsible for both the first step in magnification and for setting the limit of resolution for the entire system.

**Optic Axis:** The imaginary axis passing through an optical system, along which light travels.

**Optics:** Imaging components of the microscope. Examples include the objective, eyepiece and condenser.

# Glossary of Microscopy Terms

## P

**Phase:** A property of light in which waves are “in step” with each other. See also “In phase.”

**Phase Contrast:** A contrast-enhancement technique that detects phase objects. It uses a special ring, placed in the condenser to control location of the undiffracted light, and a matching phase plate, placed in the back focal plane of the objective. A wellbehaved phase sample will slow light by approximately one-quarter of a wavelength compared to the undiffracted background light. The phase plate is especially engineered to slow the diffracted light another quarter-wave. When the undiffracted light meets the diffracted light at the primary imaging plane to form the image, they will be out of step with each other by a half-wave, creating the condition of destructive interference and resulting in the darkening of the phase object and an improvement in contrast. Phase kits include a green filter (usually about 546 nm), which defines the wavelength for which the kit is optimized.

**Photo Adapter:** A special tube enabling cameras to be attached to the microscope.

**Pixel:** An electronic term used to describe the points of information used to map an image on a TV screen or computer monitor. Literally, a picture (“pix”) element (“el”). Each pixel carries at least the x,y location in the map and an intensity value (based on 256 gray levels).

**Plan:** An optical correction for objectives and condensers, indicating that the optical component has been corrected to produce a flat viewing field.

**Primary Image:** The first magnified image formed in the microscope.

**Primary Image Plane:** The location of the first magnified image formed by the objective.

## R

**Refraction:** Bending of light as it passes, at an angle, across a boundary between materials of different refractive index; governed by Snell’s Law.

**Refractive Index (n or  $n_i$ ):** A number describing the relationship between the velocity of light in a material of interest compared to the velocity of light in a vacuum or air. The slower the velocity in the material, the higher the refractive index.

**Resolution (R):** The smallest distance by which two objects can be separated and still be imaged as two independent objects.

**Reticle:** A small disk with an engraved or photographic pattern such as a ruler or grid, placed in the eyepiece, in the primary image plane, so that the pattern will superimpose on the image of the specimen. Used for measurement (length, angle, counting, etc.).

## S

**Snell’s Law:** The law governing refraction, relating to angles of approach and exit as light passes, at an angle, from one material to a second material of different refractive index. Snell’s Law states that light will bend toward the normal (an imaginary reference line drawn perpendicular to the surface at the point of entrance) as it passes from lower to higher refractive index.

# Glossary of Microscopy Terms

## T

**Telan Lens:** An auxiliary lens used in conjunction with an infinity corrected objective to bring light to a proper focus. In some systems, the telan lens will also correct the objective's residual chromatic aberration. See also "Tube lens."

**Trinocular Port:** A special eyepiece, usually narrower in design than conventional eyepieces, used in the photo tube of the microscope to project a real image to the film plane or detector of a camera system.

**Tube Length, Fixed:** An optical design approach in which the object is placed at some distance in front of the objective, causing the image to focus at a specific distance behind the objective. Typical distances for the mechanical tube length in these systems are either 160 mm or 170 mm.

**Tube Length, Mechanical:** The distance from the objective shoulder to the seat of the eyepiece. When replacing objectives, the mechanical tube lengths must match.

**Tube Length, Optical:** The distance between the back focal plane of the objective and the primary image plane.

**Tube Lens:** In infinity corrected optics, a lens that works along with the objective to form the image at the primary image plan. See also "Telan lens."

## W

**Wavelength:** The distance along a wave from peak to peak or trough to trough. In microscopy, wavelength is often correlated to the color and energy of light.

**White light:** Light containing all three primary colors: red + green + blue.



LAXCO, Inc.  
18303 Bothell-Everett Hwy  
Suite 140  
Mill Creek, WA 98012  
[www.laxcoinc.com](http://www.laxcoinc.com)

Contact us:  
425-686-3081  
[sales@laxcoinc.com](mailto:sales@laxcoinc.com)

LMC-MKT-DOC-1700131